



INSTALLATION INSTRUCTIONS AND SAFETY INFORMATION

FOR THE VIKING F-1 GATE OPERATOR



CLASS I, II, III AND IV
**Commercial and Residential
Vehicular Swing Gate Operator**





The F-1™ gate operator has the capacity to operate swing gate up to 1500 lbs./12 ft. or 1000 lbs./16 ft. at 100% duty cycle under extreme conditions. This efficient operator provides a solution for high traffic commercial and residential applications. The F-1™ operator offers efficiency and technology combined in a single package.

THE VIKING F-1™ SWING GATE OPERATOR

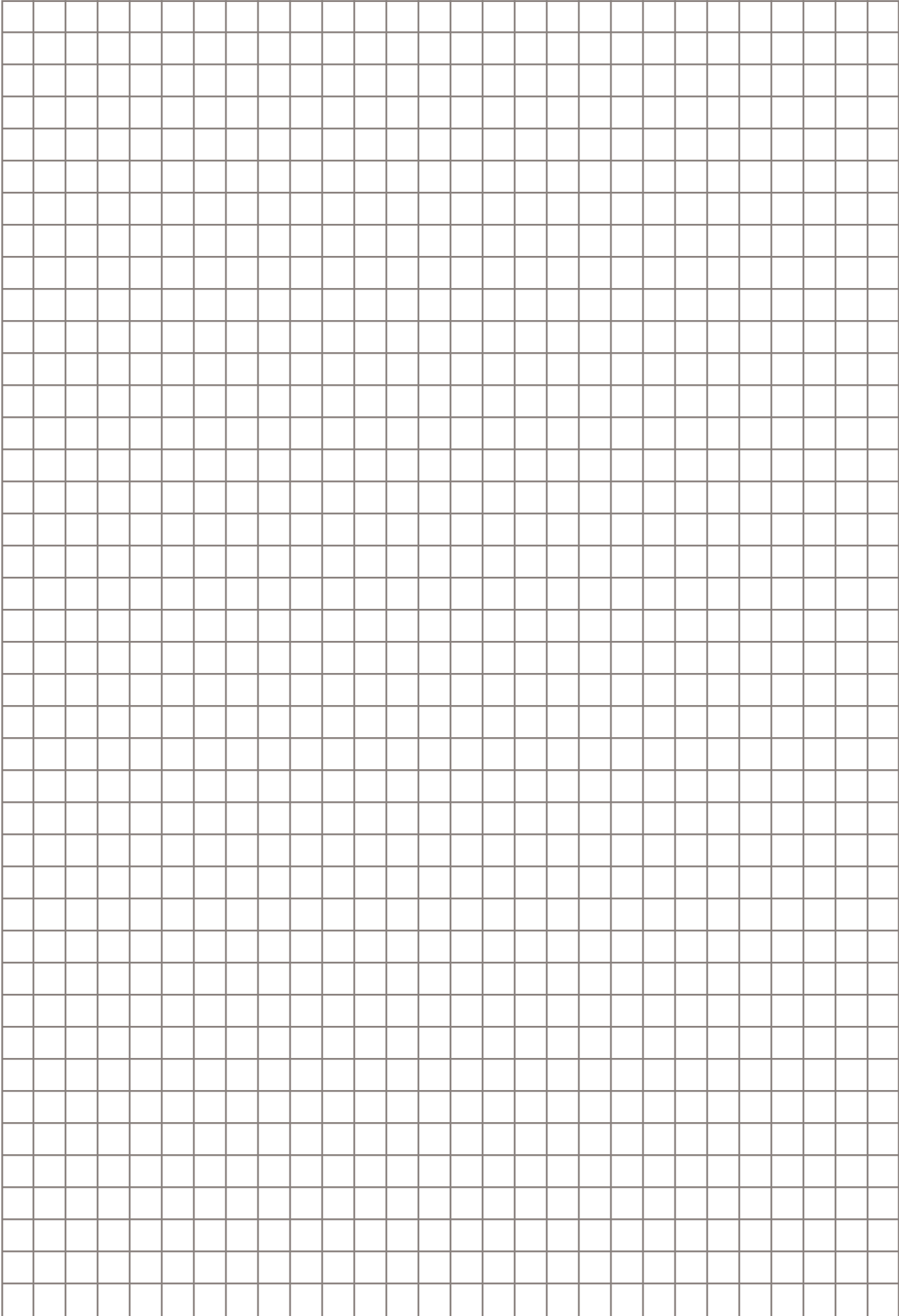

PARTS DIAGRAM:

Item	Description	Part No.
1	Operator Cover Bolt (4)	VASWCB
2	Operator Cover	VNXFICV
3	Output Shaft Knob	DWOUK10
4	Output Shaft Cover	VNXSWOSC
5	Clutch Key	VAWRCK20
6	Clutch and Handle	DWCL20
7	Output Arm	DWAR20
8	Output Shaft	DWOP20
9	Control Board	VFLEXPCBU18
10	Fuse - 15 amp	VNXF15A
11	Fuse - 4 amp	VNXF4A
12	Limit Switch Holder	DWLH10
13	Limit Switch (2)	DULS10
14	Limit Cam & Holder	DWLC10
15	Worm Gear #70 10:1	DWGB70
16	Sprocket (Gearbox)	VASP3034
17	Chain #40x46 Pitches	DWCA10
18	Sprocket (Motor)	VASP1034
19	24V DC Gearhead Motor	VAFIMO
20	Brush Kit	VAMBK
21	Chassis	VNXFICH
22	Loop Rack	VA-LR
23	Battery Switch	DUMRS10
24	Motor Switch	DUMRS10
25	Battery	DUBA12
26	Modular Power Box Assembly	VNXMPB
27	Toroid Transformer - 10 amp	DUTT10
28	Power Box Panel Assembly	VNXUPBPA
29	120V Receptacle	VA120PL
30	Main Power Switch	DUMRS10
31	Alarm	DUAL10
32	Power Harness	VNXSWPH
33	Limit Switch Harness	VNXFILSH
34	Multi-Part Arm Assembly (Standard)	VA-FIARM20
Option Swivel Arm Assembly (for inclines up to 10°)		VAFISWL20

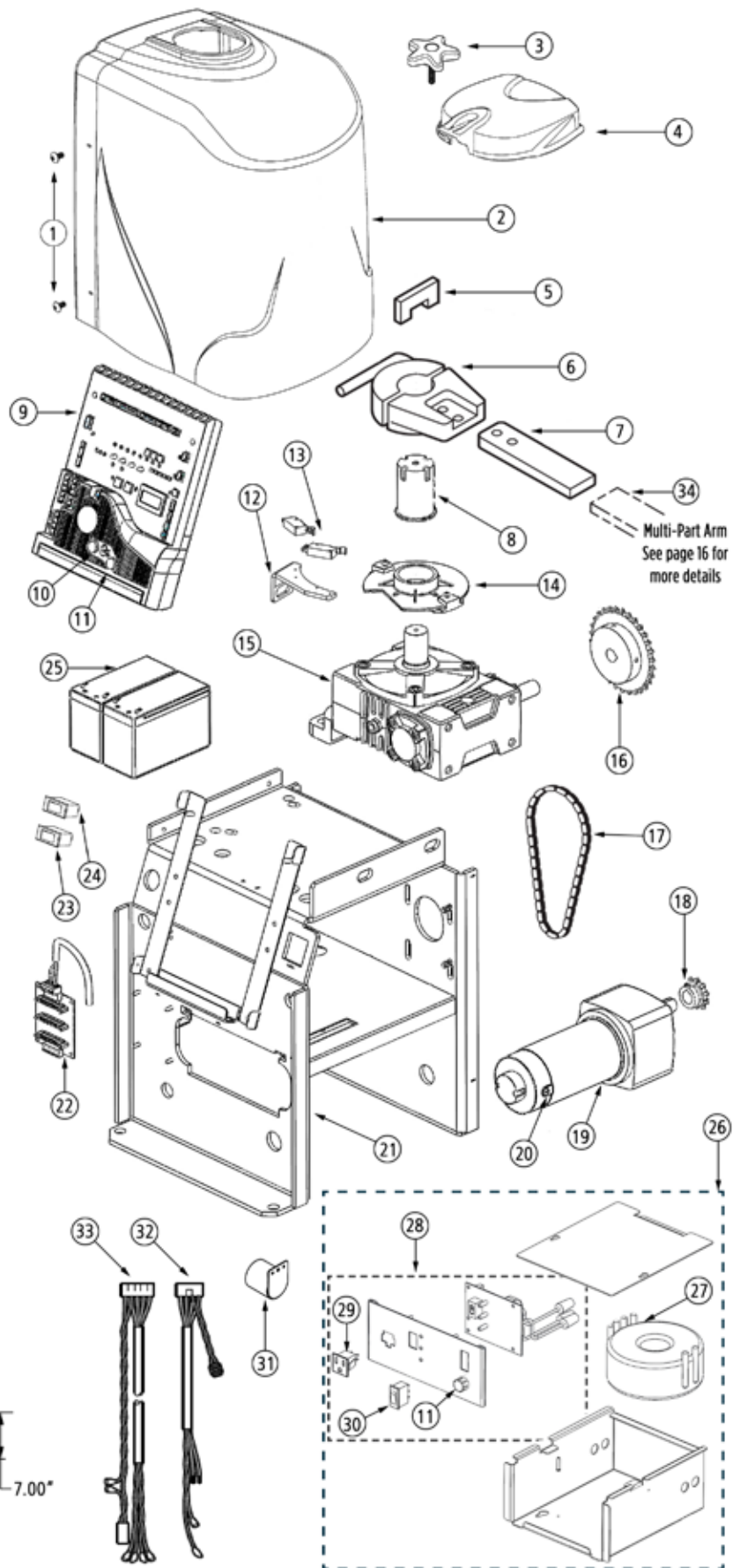

Overall Dimensions

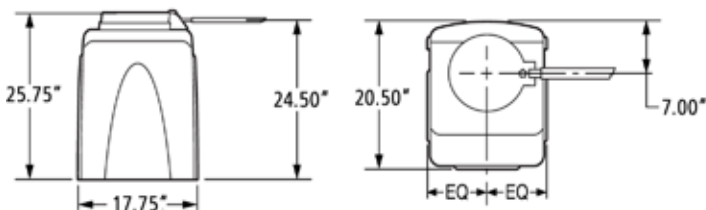

OPERATOR REFERENCES:



1. COVER BOLTS
2. OUTPUT SHAFT COVER (HAT)
3. MAIN COVER ASSEMBLY
4. MANUAL RELEASE HANDLE
releases the clutch to allow for manual operation
5. CLUTCH KEY
install if application does not require clutch to slip;
remove to manually operate the gate
6. OUTPUT ARM
connects the Arm Assembly to Clutch & Handle
Assembly
7. VFLEX CONTROL BOARD
8. MOTOR SWITCH
discontinues power to the motor; also serves as
a breaker that will self-trip to protect the motor
circuitry
9. BATTERY SWITCH
disconnects batteries from the charging circuit
during troubleshooting
10. MAIN AC POWER SWITCH
discontinues the 115/230VAC power supplied to the
operator
11. EMI FUSE
main power supply protection
12. MODULAR POWER BOX ASSEMBLY
removable; provides a convenient solution for
optional low voltage installations
13. LOOP RACK
for convenient loop detector installation
14. J-BOX
high voltage power supply connection
15. COVER BOLT MOUNTING BRACKET

CONTROL BOARD REFERENCES:

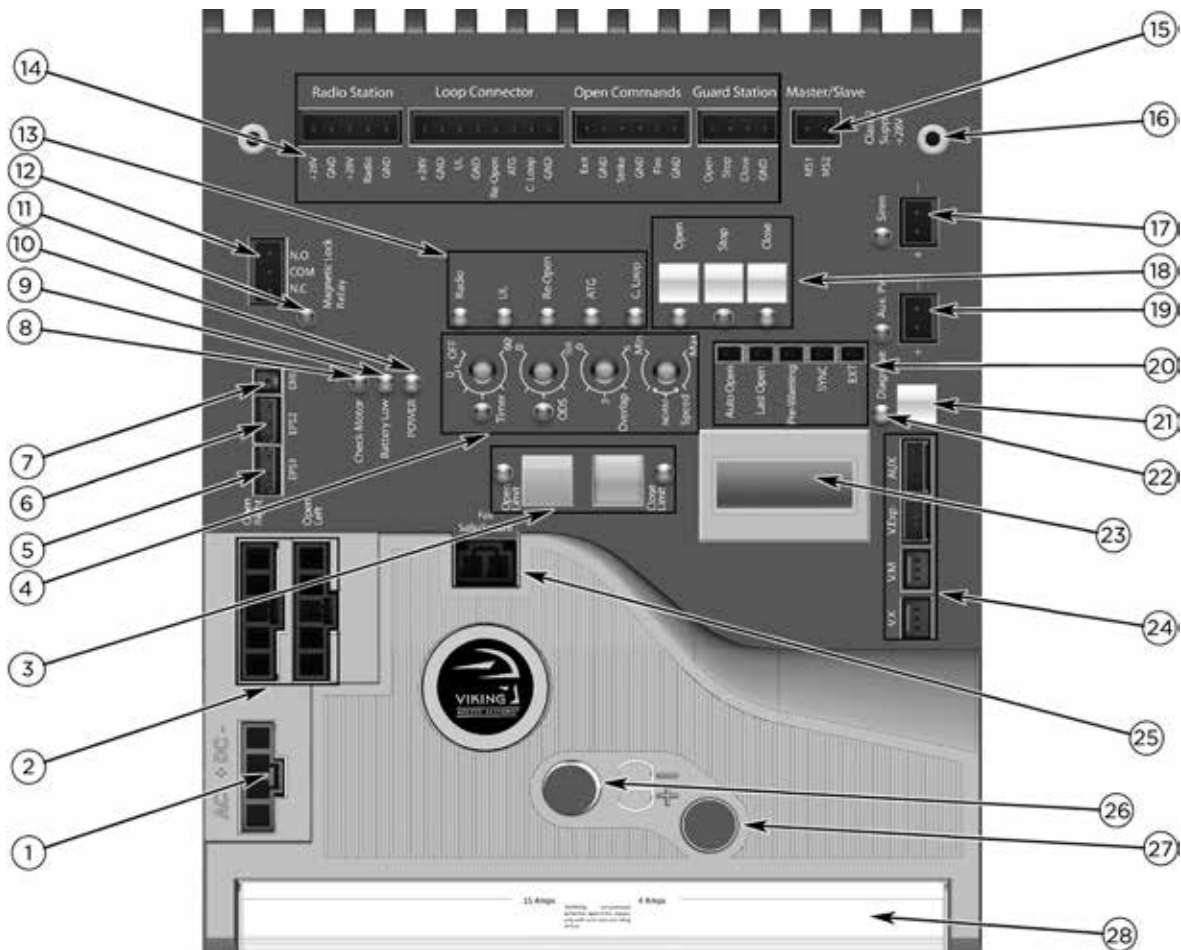

- | | | |
|---|---|---|
| <p>1. POWER HARNESS CONNECTOR provides power to the control board. pg 18-19</p> <p>2. "OPEN LEFT" & "OPEN RIGHT" provides power to the motor. pg 20</p> <p>3. LIMIT SETUP BUTTONS available for future developments.</p> <p>4. FEATURE ACTIVATION TRIM POTS activate and set features. pg 24</p> <p>5. "EPS1" CONNECTOR available for future developments.</p> <p>6. "EPS2" CONNECTOR available for future developments.</p> <p>7. EMI BOARD CONNECTOR monitors the high voltage power supply.</p> <p>8. "CHECK MOTOR" Status LED indicates motor power status. pg 36</p> <p>9. "BATTERY LOW" Status LED indicates battery power status. pg 36</p> <p>10. "POWER" Status LED control board power status. pg 18,36</p> | <p>11. "MAGNETIC LOCK RELAY" Status LED status of this on-board relay. pg 34, 36</p> <p>12. "MAGNETIC LOCK RELAY" Terminal Block connect electric locks here. pg 34, 36</p> <p>13. INPUT STATUS LEDs indicates input status. pg 36-37</p> <p>14. ACCESS CONTROL TERMINAL BLOCKS accessory connections. pg 29-32, 42-44</p> <p>15. "MASTER/SLAVE" Terminal Block wired master/slave connection. pg 22</p> <p>16. CONTROL BOARD MOUNTING HOLES secures and grounds the control board.</p> <p>17. "Siren" Terminal Block Vikings UL Siren is connected here.</p> <p>18. ON-BOARD 3 BUTTON STATION controls the gate during set up.</p> <p>19. "AUX. PWR" Terminal Block used for solar applications & in-motion warning devices. pg 19, 25</p> <p>20. FEATURE ACTIVATION PIN HEADERS activate features by placing a jumper onto the pin headers. pg 25</p> | <p>21. "DIAGNOSE" Button allows you to navigate through the Diagnostics LCD Display. pg 38-40</p> <p>22. "DIAGNOSE" LED informs that errors have been detected and available on LCD Display. pg 38-40</p> <p>23. LCD DIAGNOSTICS DISPLAY provides error messages, diagnostics and operator status information. pg 38-40</p> <p>24. EXPANSION PRODUCT CONNECTIONS connections for additional products from Viking Access Systems. pg 46</p> <p>25. "FAIL SAFE/SECURE" Jumper power failure option. pg 25</p> <p>26. FUSE HOLDER - 15 AMP for motor circuit.</p> <p>27. FUSE HOLDER - 4 AMP for charging circuit.</p> <p>28. HEAT SINK secures the control board and dissipates heat.</p> |
|---|---|---|

TABLE OF CONTENTS:

PARTS DIAGRAM/PARTS LIST	2
OPERATOR REFERENCES	3
CONTROL BOARD REFERENCES	4
IMPORTANT SAFETY INFORMATION	6-12
Important Safety Instructions.....	6
Important Installation Instructions.....	7
Maintenance.....	8
General Safety Precautions.....	8-9
Operator Classification.....	9
Entrapment Protection Requirements.....	10
Entrapment Protection Installation.....	11
Manual Release.....	11
Audible Alarm Reset Installation.....	12
Warning Placard Installation.....	12
IMPORTANT INSTALLATION INFORMATION	13
Specifications.....	13
GATE OPERATOR INSTALLATION	14-17
Concrete Pad Option.....	14
Post Mounting Option.....	15
Operator Positioning.....	16-17
ELECTRICAL INSTALLATION	18-19
High Voltage Supply Option.....	18
Low Voltage Supply Option.....	19
Solar Supply Option.....	19
LIMITS SETUP	20-21
MASTER/SLAVE SET UP	22-23
Two Wire Communication.....	22
Wireless Communication Options.....	23
CONTROL BOARD SETUP	24-27
Initial Settings.....	24-25
Obstruction Detection Sensor (ODS).....	26
Heater, Lock Mode.....	27
ACCESSORY CONNECTIONS	28-35
UL, Re-Open (Monitored Input Terminals).....	28-29
Radio Receiver (Typical).....	30
Anti-Tail Gate, Open Commands, Guard Station.....	31
Viking Loop Rack.....	32
Guidelines for Loop Installations.....	33
Magnetic Lock, Lock Solenoid.....	34
Barrier Arm Synchronization.....	35
TROUBLESHOOTING	36-41
LED References.....	36-37
LCD Display References.....	38-40
Solutions.....	41
APPENDIX A, B, C	42-45
VIKING EXPANSION PRODUCTS	48

IMPORTANT SAFETY INFORMATION

 **WARNING! Not Following these instructions may cause severe injury or death.**

IMPORTANT SAFETY INSTRUCTIONS

 **WARNING! To reduce the risk of severe injury or death.**

1. READ AND FOLLOW ALL INSTRUCTIONS.
2. Never let children operate or play with gate controls. Keep the remote away from children.
3. Always keep people and objects away from the gate. **NO ONE SHOULD CROSS THE PATH OF THE MOVING GATE.**
4. Test the gate operator monthly. The gate **MUST** reverse on contact with a rigid object or when an object activates the non-contact sensors. After adjusting the force or the limit travel, retest the gate operator. Failure to adjust and retest the gate operator properly can increase the risk of injury or death.
5. Use the emergency release only when the gate is not moving.
6. **KEEP GATES PROPERLY MAINTAINED.** Read the user's manual. Have a qualified service person make repairs to gate hardware.
7. The entrance is for vehicles only. Pedestrians must use a separate entrance.
8. **Every gate operator installation MUST have secondary protection devices against entrapment, such as edge sensors and photo beams more in particularly in places where the risk of entrapment is more likely to occur.**
9. SAVE THESE INSTRUCTIONS.

IMPORTANT INSTALLATION INSTRUCTIONS

1. Install the gate operator only when:
 - a. The operator is appropriate for the construction of the gate and usage Class of the gate (refer to page 9),
 - b. All openings of a horizontal slide gate are guarded or screened from the bottom of the gate to a minimum of 6 feet (1.83 m) above the ground to prevent a 2-1/4 inch (57.2 mm) diameter sphere from passing through the openings anywhere in the gate, and in that portion of the adjacent fence that the gate covers in the open position,
 - c. **ALL EXPOSED PINCH POINTS ARE ELIMINATED OR GUARDED, AND**
 - d. **GUARDING IS SUPPLIED FOR EXPOSED ROLLERS.**
2. The Operator is intended for installation only on gates used for vehicles. Pedestrians must be supplied with a separate access opening. The pedestrian access opening shall be designed to promote pedestrian usage. Locate the gate such that persons will not come into contact with the vehicular gate during the entire path of travel of the vehicular gate.
3. The gate must be installed in a location so that enough clearance is supplied between the gate and adjacent structures when opening and closing to reduce the risk of entrapment. Swinging gates shall not open in to the public access areas.
4. The gate must be properly installed and work freely in both directions prior to the installation of the gate operator. Do not over-tighten the operator clutch or pressure relief valve to compensate for a damaged gate.
5. The gate operator controls must be placed so that the user has full view of the gate area when the gate is moving **AND AWAY FROM THE GATE PATH PERIMETER.**
6. Controls intended for user activation must be located at least six feet (6') away from any moving part of the gate and where the user is prevented from reaching over, under, around or through the gate to operate the controls.

Exception: Emergency access controls only accessible by authorized personnel (i.e. fire, police, EMS) may be placed at any location in the line-of-sight of the gate.

IMPORTANT SAFETY INFORMATION

⚠ WARNING! Not Following these instructions may cause severe injury or death.

IMPORTANT INSTALLATION INSTRUCTIONS (Continued)

7. The Stop and/or Reset button must be located in the line-of-sight of the gate. Activation of the reset control shall not cause the operator to start.
8. A minimum of two (2) WARNING SIGNS shall be installed, in the area of the gate. Each placard is to be visible by persons located on the side of the gate on which the placard is installed.
9. **For gate operators using non-contact sensors (photoelectric beam or like) in accordance with section 32.1.1 of the UL standard:**
 - a. See instructions on the placement of non-contact sensors for each type of application (refer to page 10).
 - b. Care shall be exercised to reduce the risk of nuisance tripping, such as when a vehicle, trips the sensor while the gate is still moving, and
 - c. One or more non-contact sensors shall be located where the risk of entrapment or obstruction exists, such as the perimeter reachable by a moving gate or barrier (refer to page 10).
 - d. For UL compliance: Use only Omron: E3K-R10K4-NR-1 // EMX: IRB-RET, IRB-MON // Miller Edge: RG-K-R, PG-K-R100, PG-K-R50, MIM-62
For ETL compliance: Use only Seco-Larm E-931-33PRGQ, E-936-S45RRGQ, E-931-S5ORRGQ, E-960-D90GQ // EMX NIR-50-325
10. **For a gate operator utilizing a contact sensor (edge sensor or like) in accordance with section 32.1.1 of the UL 325 standard:**
 - a. One or more contact sensors shall be located where the risk of entrapment or obstruction exists, such as a the leading edge, trailing edge, and post mounted both inside and outside of a vehicular horizontal slide gate (refer to page 10).
 - b. One or more contact sensors shall be located at the bottom of a vehicular vertical lift gate.
 - c. One or more contact sensors shall be located at the pinch point of a vehicular vertical pivot gate.
 - d. A hardwired contact sensor shall be located and its wiring arranged so that the communication between the sensor and the gate operator is not subject to mechanical damage.
 - e. A wireless contact sensor such as one that transmits radio frequency (RF) signals to the gate operator for entrapment protection functions shall be located where the transmission of the signals are not obstructed or impeded by building structures, natural landscaping or similar obstructions. A wireless contact sensor shall function under the intended end-use conditions.
 - f. One or more contact sensors shall be located on the inside and outside leading edge of a swing gate. Additionally, if the bottom edge of a swing gate is greater than 6 inches (152 mm) but less than 16 inches (406 mm) above the ground at any point in its arc of travel, one or more contact sensors shall be located on the bottom edge.
 - g. One or more contact sensors shall be located at the bottom edge of a vertical barrier (arm).
 - h. For UL compliance: Use only EMX: WEL-200K // Miller Edge: ME110 through ME117, ME120, ME123, MG020, MGR20, MGS20, RB-G-K10, MIM-62 // ASO: 25.30, 25.45, 95.20

IMPORTANT SAFETY INFORMATION

 **WARNING! Not Following these instructions may cause severe injury or death.**

MAINTENANCE

Remove the Power Harness from the Control Board. (refer to page 18)

- Clean and lubricate the turning pins and gate hinges using the recommended lubricant.
- Check that all hardware of the gate operator is properly tighten.
- Ensure that the gate moves freely.
- Check for corroded parts and replace if necessary.
- Check the battery for the following:
 - Battery connections must be free of corrosion.
 - Battery voltage must be 26VDC (fully charged battery).

Reconnect the Power Harness for the Control Board. (refer to page 18)

- Check and confirm the proper operation of all safety devices (photoelectric eye, edge sensors or like).
- Check and confirm the operation of all installed accessories.
- Check and confirm the operation of all special features such as the Intelligent Obstruction Sensor, Hold Open Timer. (refer to page 24 and 26)
- Check and confirm the operation of the manual release. (refer to page 11)
- Verify the functionality of the battery backup, or power failure option, by turning off the main power source (115VAC or 230VAC). **DO NOT FORGET TO TURN ON THE MAIN POWER SOURCE AFTER VERIFICATION.**

GENERAL SAFETY PRECAUTIONS

The following precautions are an integral and essential part of the product and must be supplied to the user. Read them carefully as they contain important indications for the safe installation, use and maintenance.

- These instruction must be kept and forwarded to all possible future users of the system.
- This product must be used only for that which it has been expressly designed.
- Any other use is to be considered improper and therefore dangerous.
- The manufacturer cannot be held responsible for possible damage caused by improper, erroneous or unreasonable use.
- Avoid operating in the proximity of the hinges or moving mechanical parts.
- Do not enter the path of the moving gate while in motion.
- Do not obstruct the motion of the gate as this may cause a situation of danger.
- Do not allow children to play or stay within the path of the moving gate.
- Keep remote control or any other control devices out of the reach of children, in order to avoid possible involuntary activation of the gate operator.
- In case of break down or malfunctioning of the product, disconnect from the main power source. Do not attempt to repair or intervene directly, contact only qualified personnel for repair.
- Failure to comply with the above may create a situation of danger.
- All cleaning, maintenance or repair work must be carried out by qualified personnel.
- In order to guarantee that the system works efficiently and correctly it is important to have the manufacturer's instructions on maintenance of the gate and operator carried out by qualified personnel.
- In particular, regular checks are recommended in order to verify that the safety devices are operating correctly.

All installation, maintenance and repair work must be documented and made available to the user.

IMPORTANT SAFETY INFORMATION

CAUTION: To Reduce the Risk of Fire or Injury to Persons:

- a. Use only the following type and size battery(ies): Yuasa NP7-12 or VIKING DUBA12
- b. Do not dispose of the battery(ies) in fire. The cells may explode. Check with local codes for possible disposal instructions.
- c. Do not open or mutilate the battery(ies). Released electrolyte is corrosive and may cause damage to the eyes or skin. It may be toxic if swallowed.
- d. Exercise care in handling batteries in order not to short the battery with conducting materials such as rings, bracelets and keys.
- e. Change the battery(ies) provided with or identified for use with this product only in accordance with the instructions and limitations specified in this manual.
- f. Observe proper polarity orientation between the battery(ies) and charging circuit.
- g. Do not mix batteries of different sizes or from different manufactures in this product (applies to products employing more than one user replaceable secondary battery).
- h. A battery-operated product employing a secondary battery supply intended to be charged within the product shall contain specific instructions concerning the proper method of charging.

UL325 Gate Operator Classifications

GLOSSARY

RESIDENTIAL VEHICULAR GATE OPERATOR

CLASS I - A vehicular gate operator (or system) intended for use in garages or parking areas associated with a residence of one-to four single families.

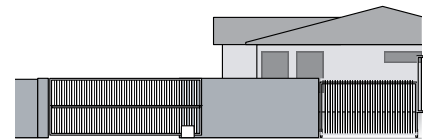

COMMERCIAL/GENERAL ACCESS VEHICULAR GATE OPERATOR

CLASS II - A vehicular gate operator (or system) intended for use in a commercial location or building such as a multi-family housing unit (five or more single family units), hotel, garages, retail store, or other building servicing the general public.

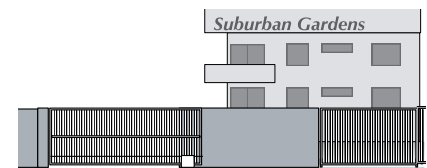

INDUSTRIAL/LIMITED ACCESS VEHICULAR GATE OPERATOR

CLASS III - A vehicular gate operator (or system) intended for use in an industrial location or building such as a factory or loading dock area or other locations not accessible by or intended to service the general public.

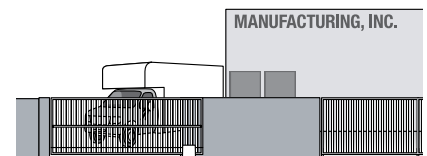

RESTRICTED ACCESS VEHICULAR GATE OPERATOR

CLASS IV - A vehicular gate operator (or system) intended for use in a guarded industrial location or building such as an airport security area or other restricted access locations not servicing the general public, in which unauthorized access is prevented via supervision by security personnel.

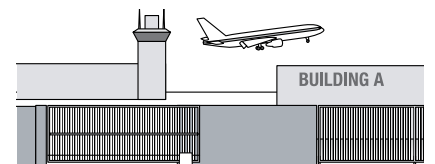

Install the gate operator only when:

The operator is appropriate for the construction of the gate and the Usage Class of the gate.

IMPORTANT SAFETY INFORMATION

⚠ WARNING! Not Following these instructions may cause severe injury or death.

Monitored Entrapment Protection Requirements

IMPORTANT: MONITORED PROTECTION MUST BE INSTALLED

- **REQUIRED BY UL 325, an approved MONITORED entrapment protection sensor is REQUIRED to be installed in all areas accessible to potential entrapment and pinch points.**
- For a horizontal swing gate operator, at least one Monitored External Entrapment Sensor is required in each direction of travel. Except, if there is no entrapment zone in one direction of travel, it is not required to have a Monitored Entrapment sensor for that direction of travel.
 - ⚠ If there is a possible entrapment zone in the open direction, an external sensor MUST be connected to the “UL” input or the installation will not comply with UL 325.
 - ⚠ An external sensor connected to the “Re-Open” input terminal will protect against entrapment ONLY in the closing direction.
- The installed sensor MUST be “**10K Resistor Based**”.
- You may connect up to FOUR monitored sensors, wired in parallel, to either the “UL” and/or “Re-Open” terminals, for a total of 8 monitored sensors.
- **Failure to install the required monitored entrapment protection sensor(s) may render the gate operator INOPERABLE. The gate can be moved manually. Refer to page 11.**
- Consult the installation manual of the sensor for detailed information about the usage, installation and maintenance.
- Use only UL Recognized Component Edge Sensors and Photoelectric Sensors. Refer to pg 7.

SWING GATE ENTRAPMENT ZONE – Locations between a moving gate or moving, exposed operator components and a counter opposing edge or surface where entrapment is possible up to 1.8 m (6 ft) above grade. Such locations occur if during any point in travel:

- a. The gap between the bottom of a moving gate and the ground is greater than 101.6 mm (4 in) and less than 406 mm (16 in); or
- b. The distance between the center line of the pivot and the end of the wall, pillar, or column to which it is mounted when in the open or closed position exceeds 101.6 mm (4 in). Any other gap between a moving gate and fixed counter opposing edges or surfaces or other fixed objects is less than 406 mm (16 in) (examples are walls, curbs, berms or other immovable objects).

Photoelectric Sensor (non-contact sensor)

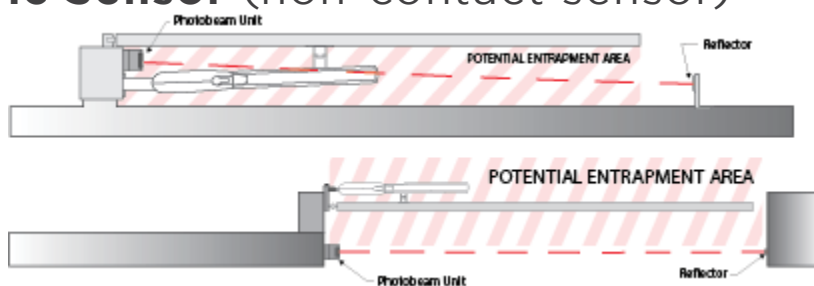

Edge Sensor (contact sensor)

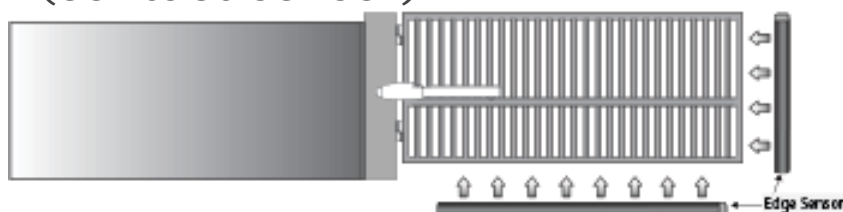

IMPORTANT SAFETY INFORMATION

⚠ WARNING! Not Following these instructions may cause severe injury or death.
⚠ Cable use in Class 2 circuit to an external device shall be type CL2, CL2P, CL2R, CL2X or other cable with equivalent or better electrical, mechanical, and flammability ratings.

Monitored Entrapment Protection Installation

⚠ IMPORTANT: A minimum of one Monitored External Entrapment Sensor is required to be connected to the UL terminal OR the Re-Open terminal. If there is a possible entrapment zone in the open direction, an external sensor **MUST** be wired to the “UL” input or the installation will not comply with UL 325.

“UL” Protects against entrapment in both the opening and closing directions. Input will reverse the gate momentarily in the opposite direction it was traveling. Refer to page 28.

“Re-Open” Protects against entrapment in the closing direction **ONLY**. Input will reverse the gate all the way to the Open Limit. Refer to page 29.

STEP 1: Connect the monitored entrapment protection sensor(s) to the Viking control board as illustrated.

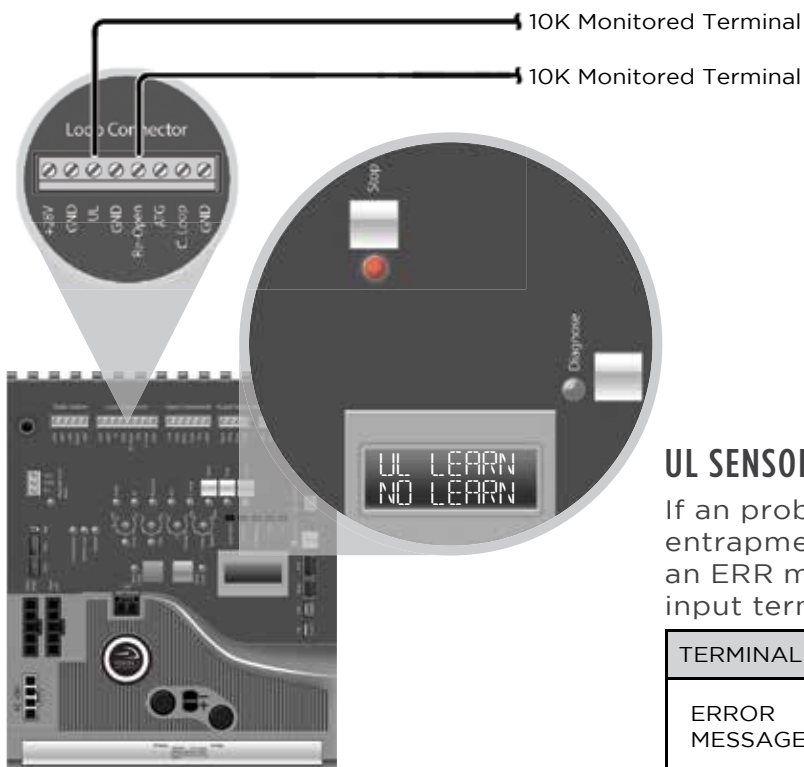

STEP 2:

Execute the Learn Process:

- Toggle the “Diagnose” button until you see UL LEARN NO LEARN on the LCD Display.
- Press and hold the “Stop” button.
- Toggle the “Diagnose” button once.
- The number of Monitored sensors connected to the “UL” or Re-Open terminals will now be displayed.

EXAMPLE: UL LEARN
 UL2 RO1

UL SENSOR ERRORS:

If an problem occurs with one of the monitored entrapment sensors, the “Stop” LED will flash and an ERR message will be displayed, indicating which input terminal(s) the sensor is connected to.

TERMINAL:	“UL”	“Re-Open”	“UL” & “Re-Open”
ERROR MESSAGE:	ERR SENS UL	ERR SENS RO	ERR SENS UL RO

Manual Release

When manual operation is required:

1. Remove the “Output Shaft Cover” or Hat.
2. Lift the “Manual Release Handle”.
3. Remove the “Clutch Key”.

To resume normal operation:

1. Align the notches on the Output Shaft to the clutch and reinstall the Clutch Key.
2. Push the Manual Release Handle down, back to the locked position. **Refer to page 17 for more details**

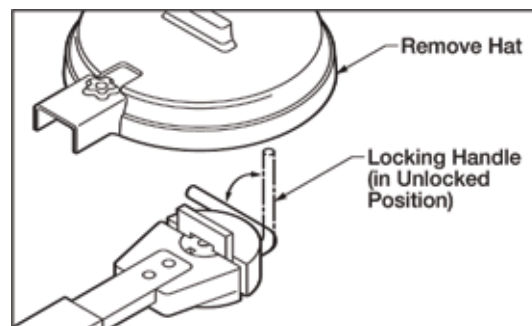

IMPORTANT SAFETY INFORMATION

⚠ WARNING! Not Following these instructions may cause severe injury or death.

Audible Alarm Reset Switch Installation

Manual Reset for the Audible Alarm

- UL325 standard requires an audible alarm to sound after two consecutive events detected by the inherent entrapment protection of the gate operator (obstruction sensor).
- The audible alarm will continue to sound for 5 minutes or until a stop command gets actuated.
- The Stop command can be actuated in two different forms:
 1. Using the Built in Stop switch on the Control Board or;
 2. Using an External Stop button within the sight of the gate, away from moving parts of the gate and out of reach of children.
 - a. Controls intended for user activation must be located at least six feet (6') away from any moving part of the gate and where the user is prevented from reaching over, under, around or through the gate to operate the controls. Outdoor or easily accessible controls shall have a security feature to prevent unauthorized use.
 - b. The Stop and/or Reset button must be located in the line-of-sight of the gate. Activation of the reset control shall not cause the operator to start.

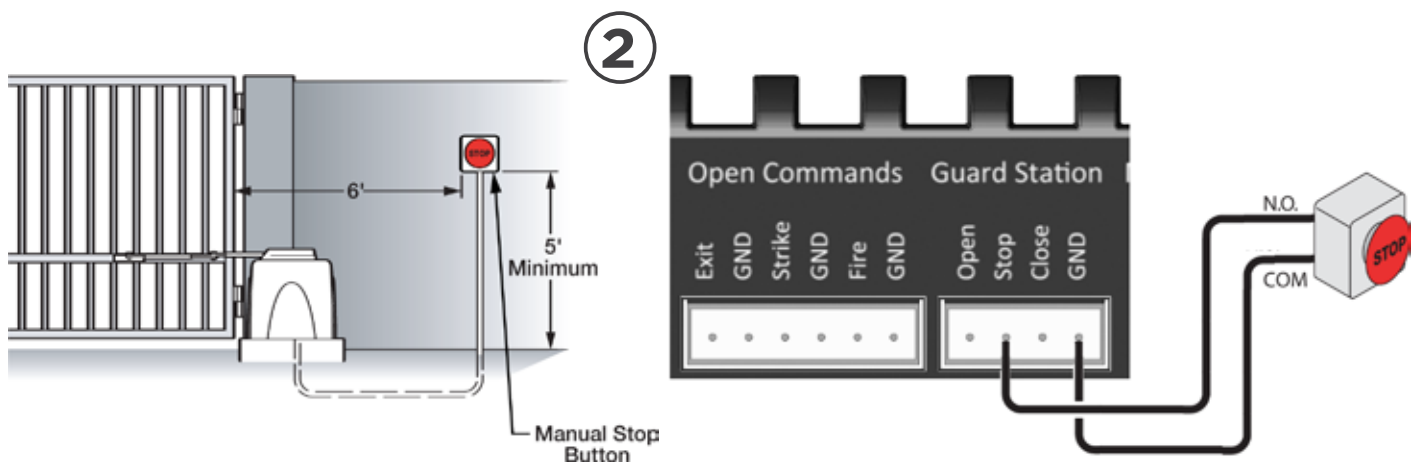

Warning Placard Installation

- All Warning Placards must be installed where visible in the area of the gate.
- A minimum of two placards shall be installed.
- A placard is to be installed in the area of each side of the gate and be visible.



IMPORTANT INSTALLATION INFORMATION

⚠ CAUTION: To Reduce the Risk of Fire or Injury to Persons:

⚠ WARNING: For use with gates at a maximum 1500 lbs. in weight or 16 ft. in length.



DO NOT allow pedestrian use of this gate

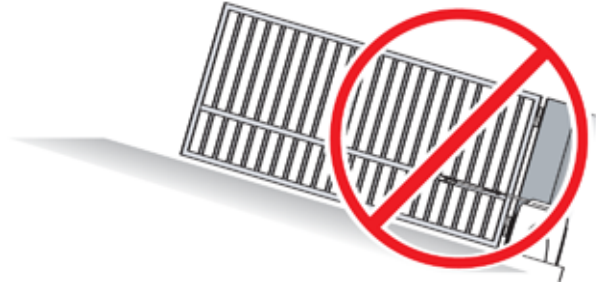

DO NOT install the gate operator to lift gates

Locate Control Buttons:

1. Within sight of the gate,
2. At a minimum height of 5 feet so small children are not able to reach it; and
3. At least 6 feet away from all moving parts of the gate.

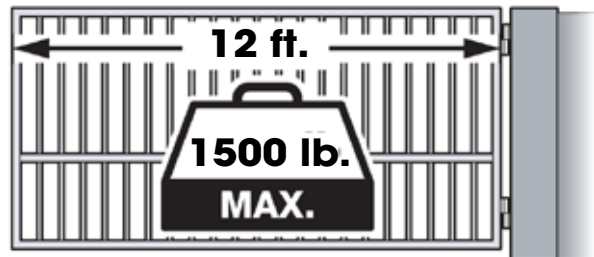
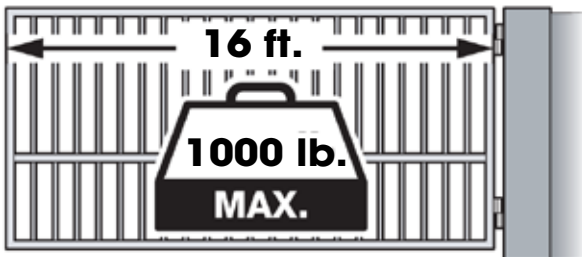

Specifications:

UL 325 Classification:	Class I, II, III and IV *Refer to page 9
Maximum Gate Length:	16 ft. / 12 ft.
Maximum Gate Weight:	1000 lb. / 1500 lb.
Operating Temperature:	-20°F (-28°C) to 160°F (71°C)
Power Requirements:	120VAC / 240VAC (5.5* Amp / 1.25 Amp) *Includes 3 amp load on receptacle Single Phase (50Hz / 60Hz)
Alternative Power	24VAC / VDC (60VA) or Solar

GATE OPERATOR INSTALLATION

Concrete Pad Option

1. Follow the local building code to determine the required depth of the concrete pad.
2. Pad measurements recommended by Viking Access Systems are at least 23" long, 20" wide and 30" deep to ensure the stable operation of the operator, and a minimum of 6" above level grade to avoid any flooding of the machinery.
3. Provide a sufficient number of conduit pathways for all low power accessories such as loop detector leads, maglock, non-contact sensors, contact sensors, safety and other commands. Also provide conduit for the power supply to the operator.

⚠ DO NOT run low voltage and high voltage wiring in the same conduit.

⚠ Provide at least 12" separation between low and high voltage conduits.

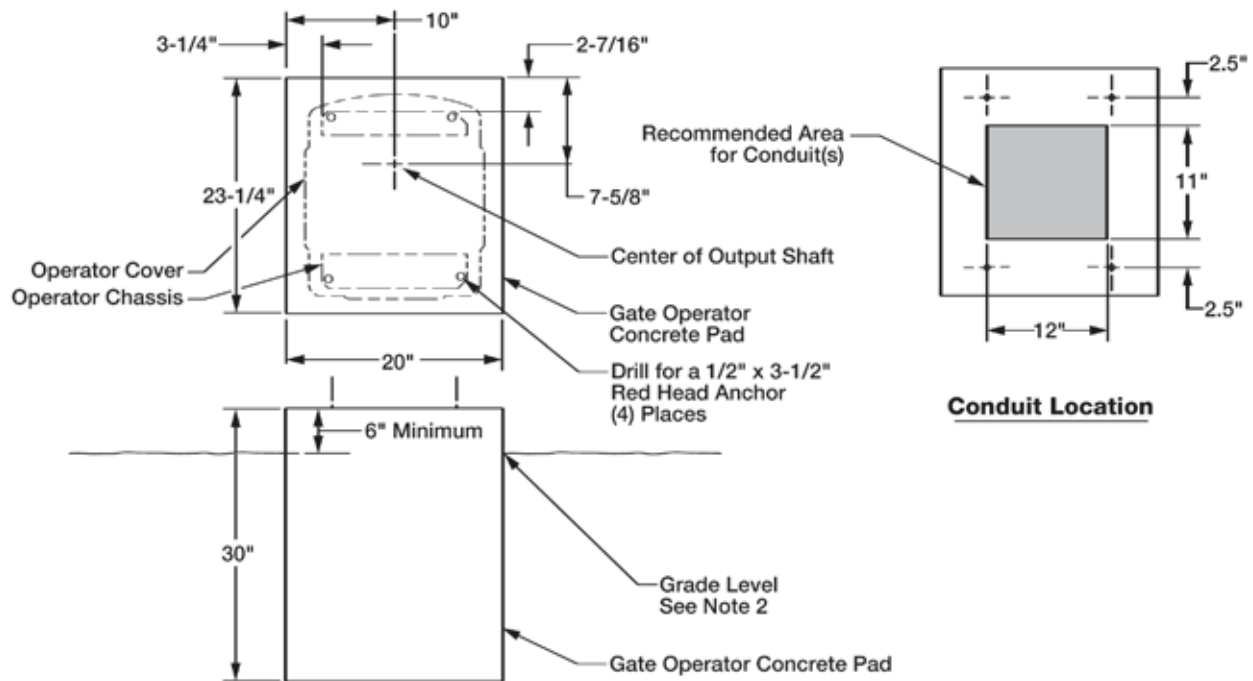

GATE OPERATOR INSTALLATION

Post Mounting Option

TIP: The operator can be post mounted to be elevated above snow and flood lines.

1. Consult the local building codes for the depth and concrete requirements.
2. Maximum 3.00" OD pipe.
3. Provide a sufficient number of conduit pathways for all low power accessories. Also provide conduit for the power supply to the operator.

⚠ DO NOT run low voltage and high voltage wiring in the same conduit.

⚠ Provide at least 12" separation between low and high voltage conduits.

REQUIRED ADD-ON: PART# VA-F1PS

- Main pieces made of 1/4" thick material
- All mounting hardware is included
- Posts and U-Bolts are not supplied

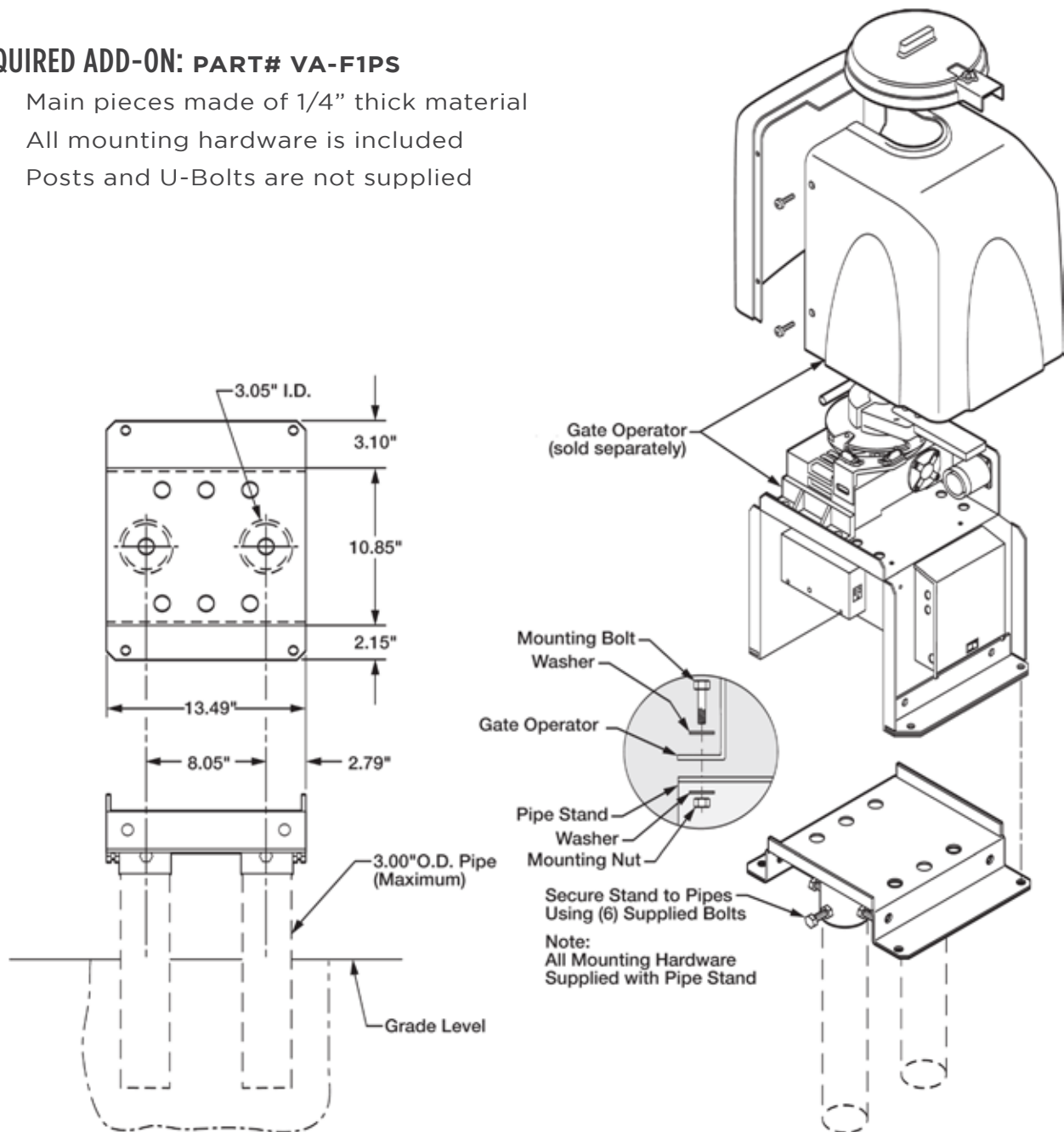

GATE OPERATOR INSTALLATION

Operator Positioning

⚠ IMPORTANT: Swing Gates must not open into public access areas.

The gate must be installed in a location so that enough clearance is supplied between the gate, while opening and closing, and adjacent structures to reduce the risk of entrapment.

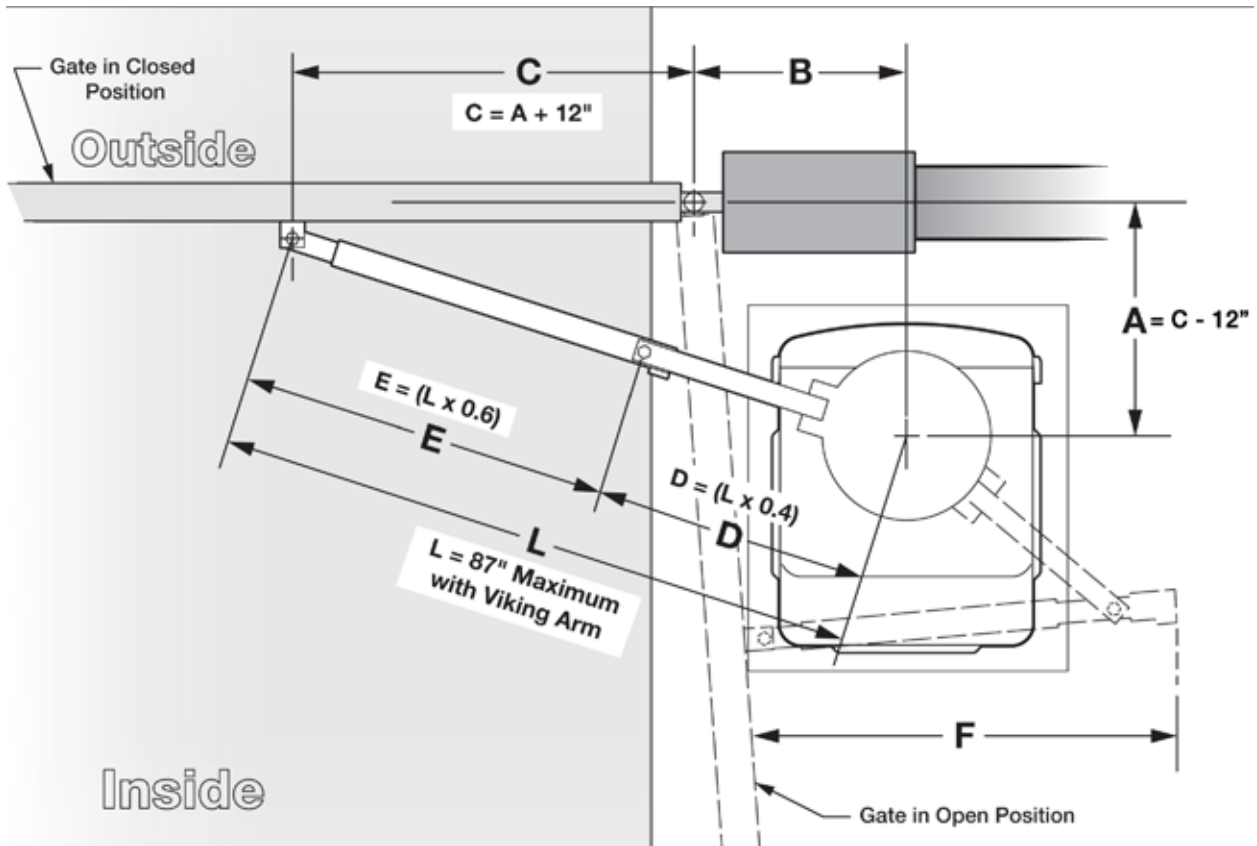

⚠ TECHNICAL TIPS: Operator and Arm Geometry

- Increasing "C" dimension provides better gate control and stability by reducing the effects of inertia and decreasing the gate leverage against the operator.
- Following to the geometrical formulas and relationships provided is recommended.

Arm Assembly: VA-F1ARM20 and VA-F1SWL20

VA-F1ARM (Standard) Typical installations. Gate travels level.

VA-F1SWL20 (Option) Gate travels on an incline, up to 10° and with a maximum pull scale force of 70 lbs. to manually pull the gate up grade,

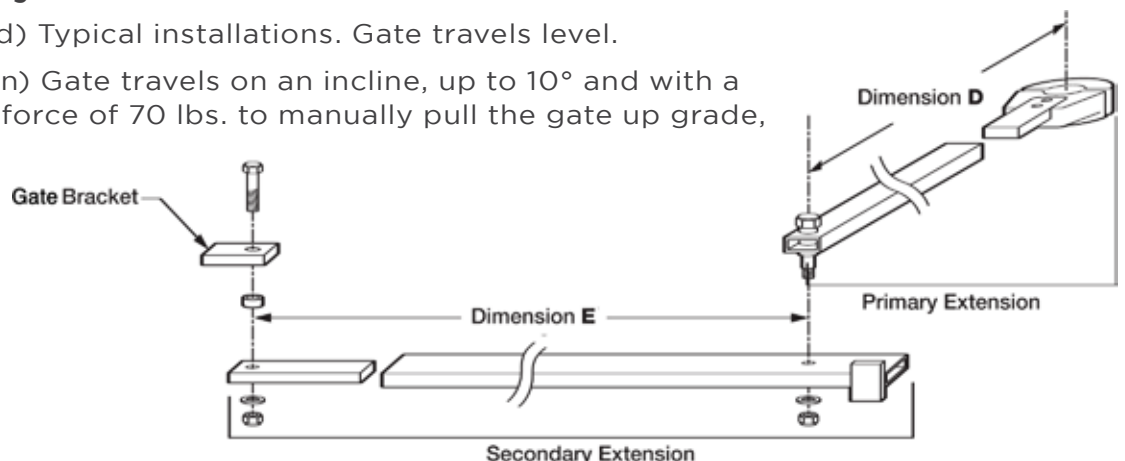

GATE OPERATOR INSTALLATION

⚠ IMPORTANT: When attaching the Arm Assembly to the gate, if the “Gate Bracket” is not welded to a frame member that runs the full length of the gate, the operator may damage the gate. Do not attach the Gate Bracket to only a few pickets.

STEP 1

Install the Clutch and cut the Arm Assembly to achieve the desired dimensions for “D” and “E” according to the formulas provided on page 16.

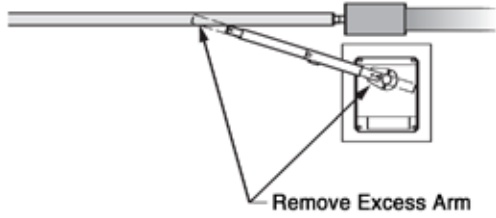

⚠ TIP: Leave some additional material when cutting the Arm Assembly to allow for adjustment.



STEP 2

With the gate at the closed, install the Arm Assembly. Check that the dimensions correspond accordingly to the formulas provided on page 16.

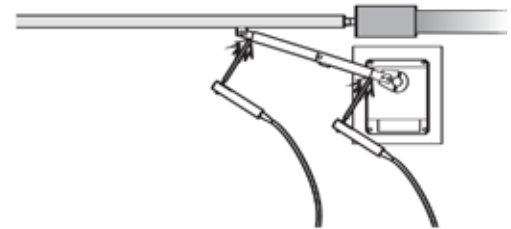

⚠ TIP: Use C-clamps or tack-weld the Arm assembly in place until Step 3 has been completed.

STEP 3

With the Clutch installed and released, manually move the gate to both limits. Verify the following:

1. The gate reaches the desired limits.
2. The Arm does not bind at any point.

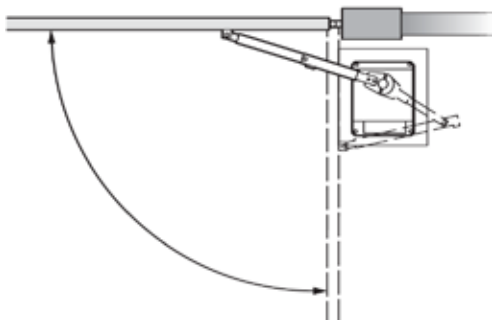

STEP 5

Rotate the Clutch until it lines up with the notches on top of the Output Shaft and insert the Clutch Key.

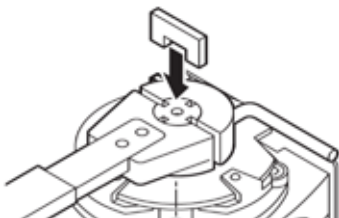

STEP 4

Once satisfied with the installation and movement of the gate, weld the arm pieces securely. Paint the Arm to protect against rusting.

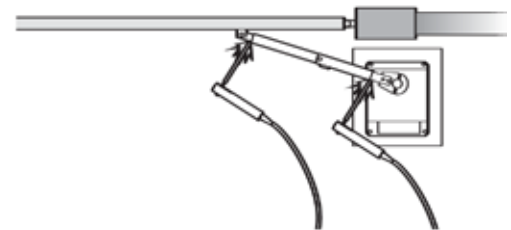

STEP 6

Verify the Clutch is adjusted properly.

- Both sides adjusted **evenly**.
- Handle is locked, **by hand**, and positioned horizontally at 0°.

With the Clutch Key removed, the Clutch should not slip with moderate force applied to the gate.

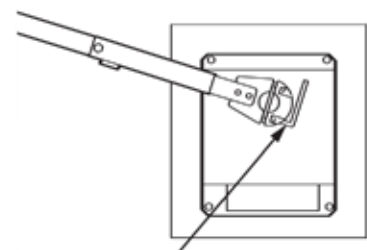

ELECTRICAL INSTALLATION

High Voltage Supply Option

⚠ Caution: Always turn off power breakers when working with high voltage. DO NOT connect the “Power Harness” to the Control Board until the electrical installation is complete and ready for verification.

STEP 1

At the “Power Box”:

- Set the “Voltage Selector” according to the supply voltage (115V or 230V).
- Turn the “AC Power” switch ON

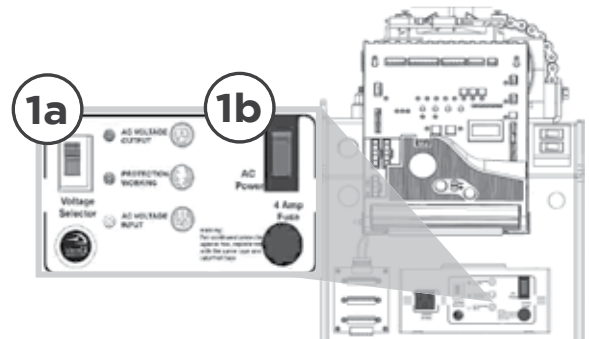

STEP 2

⚠ WARNING: SINGLE PHASE AC ONLY

At the “J-Box”:

- Connect the incoming power wires, matching the wire color codes.
- If the supply voltage is 120VAC, connect the red wire, labeled “Outlet Power”, to the neutral (white) wires.

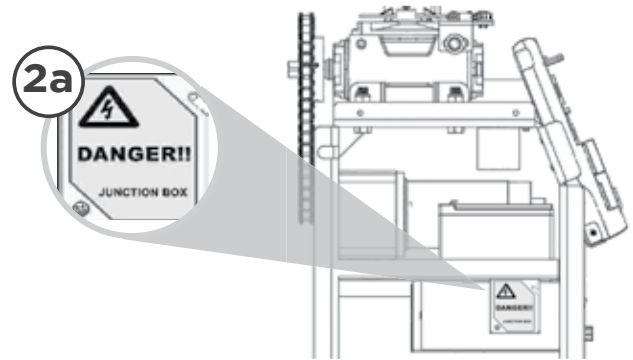

STEP 3

- Turn ON the main facility breaker
- Verify that all three (3) LEDs are illuminated at the “Power Box”.
- Turn the “Battery Switch” ON.

At the Control Board:

- Connect the Power Harness and verify the “POWER” LED is illuminated solid.

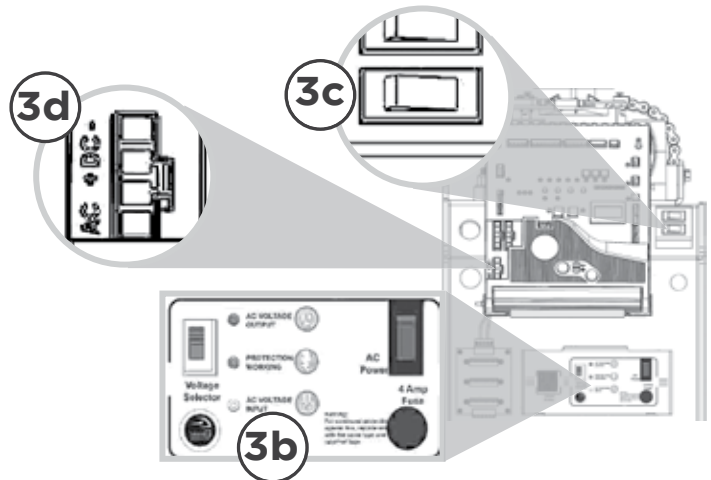

⚠ TECHNICAL TIP: If the “Power” LED is flashing or any of the 3 LEDs on the “Power Box” are not illuminated, refer to the Troubleshooting pages.

Tips for proper ground installation:

To minimize the effects caused by lightning, follow these guidelines.

- Use a ground rod to provide a ground reference.
- Consult your city code and be aware of under-ground services in the site of the gate operator to prevent inconveniences.
- Always use a single bonding point for grounding.
- All ground wires must be as short and as thick as possible.
- Prevent unnecessary turns or loops in all ground wires.

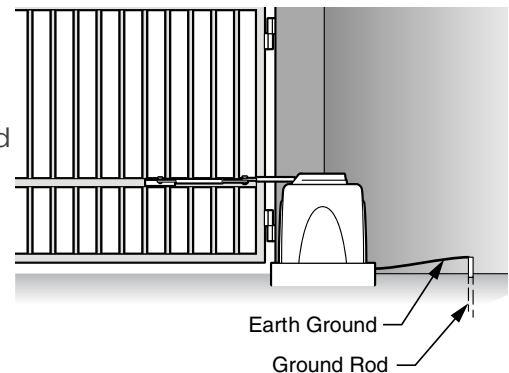

ELECTRICAL INSTALLATION

Low Voltage Supply Option

TIP: The operator is equipped with a **Modular Power Box** that can be relocated to provide power for low voltage installations. Supplies 24VAC to the operator.

⚠ Caution: Always turn off power breakers when working with high voltage. **DO NOT** connect the “Power Harness” to the Control Board until the electrical installation is complete and ready for verification.

Remove the “Power Box” from the operators chassis and relocate to the nearest high voltage source (115V or 230V single phase AC). Follow local codes or guidelines.

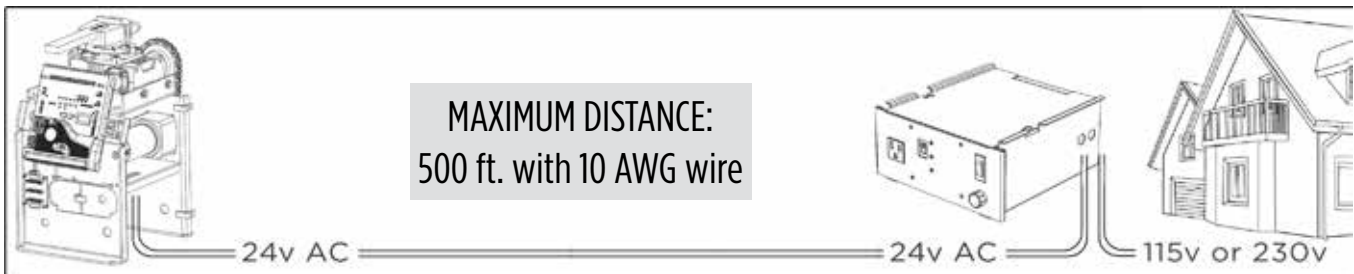

Solar Supply Option

Vikings Solar Package (**part # VA-SOCHP**) is an efficient and effective solution to powering the operator with solar energy. (See page 46 for package details)

⚠ Tip: Solar efficiency can be increased by activating the “Pre-Warning” **(A)** feature. The “Aux. Pwr” **(B)** terminals will then provide power to all nonessential controls beginning 3 seconds prior to gate movement and while the gate is moving. (page 25)

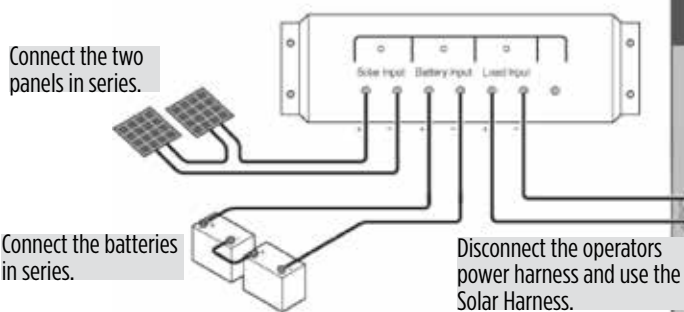

Disconnect the operators power harness and use the Solar Harness.

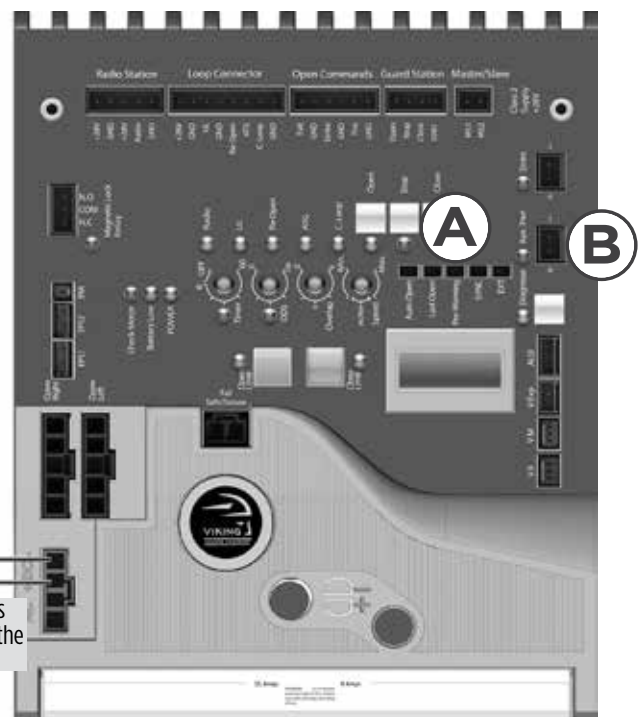

⚠ IMPORTANT: The number of cycles achieved daily is dependent on many factors, including local solar radiation data and power consumption of the motor and accessories. It is very important that you consider this when using solar power.

LIMITS SETUP

STEP 1 Connect the “Limit Switch Harness” to the Control Board.

- a. “OPEN RIGHT” Connector if the gate opens Right.
- b. “OPEN LEFT” Connector if the gate opens Left.

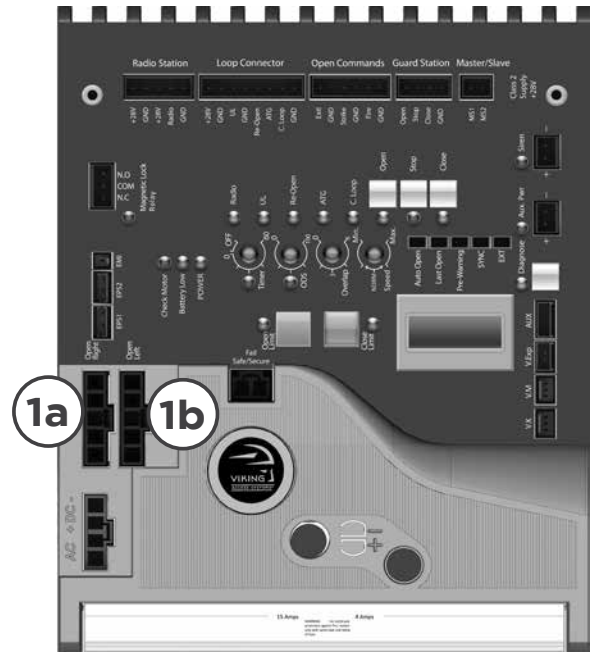
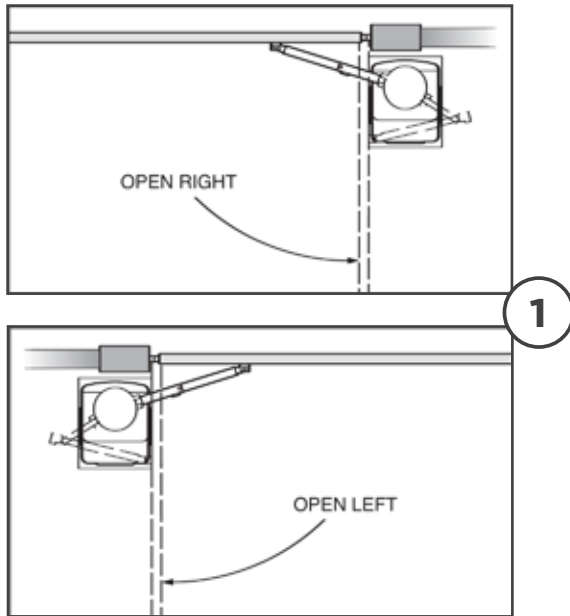

STEP 2

At the “Limit Cam & Holder” assembly:

- a. Loosen screws on both of the “Limit Switch Cams”.
- b. With the Articulating Arm and “Clutch” installed, insure that the “Clutch Guide Pin” is seated into one of the four holes on the “Cam Holder”.
- c. Move the gate manually to the desired closed limit position and adjust the nearest Limit Switch Cam to actuate the corresponding limit switch.
- d. Slight tighten the Limit Cam Screw.
- e. Repeat Step 2c & 2d for the desired open limit position.
- f. Run the 2 full cycles before confirming your limit settings. Adjust accordingly if required.

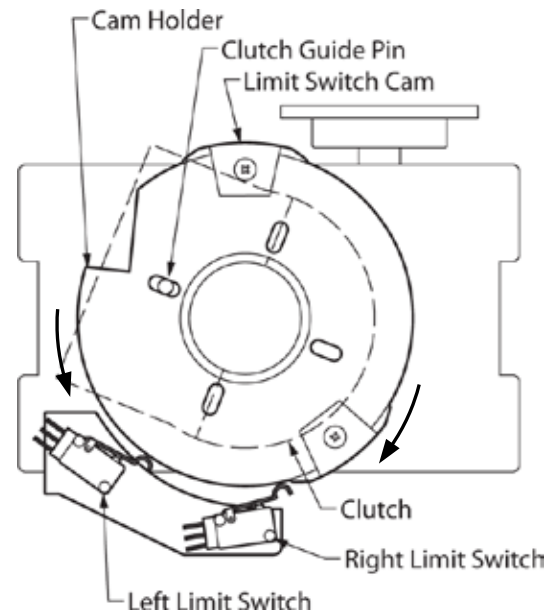

Tip: Referring to Step 2b. The “Cam Holder” contains four (4) Guide Pin holes to allow for proper positioning, if required, due to an alternative operator orientation.

Gate OPENS to the LEFT

Left Limit Switch	=	Closed Limit
Right Limit Switch	=	Open Limit

Gate OPENS to the RIGHT

Left Limit Switch	=	Open Limit
Right Limit Switch	=	Closed Limit

LIMITS SETUP

⚠ IMPORTANT: This gate operator uses mechanical limit switches. Therefore, the limits cannot be set electronically by the control board. The Limit Buttons on the control board have been rendered inactive.

⚠ TECHNICAL TIP: Each Limit LED will illuminate solid when the corresponding limit switch is actuated. The LEDs will flash simultaneously while both limit switches are actuated at the same time. This display may indicate a problem with the limit switches or wires.

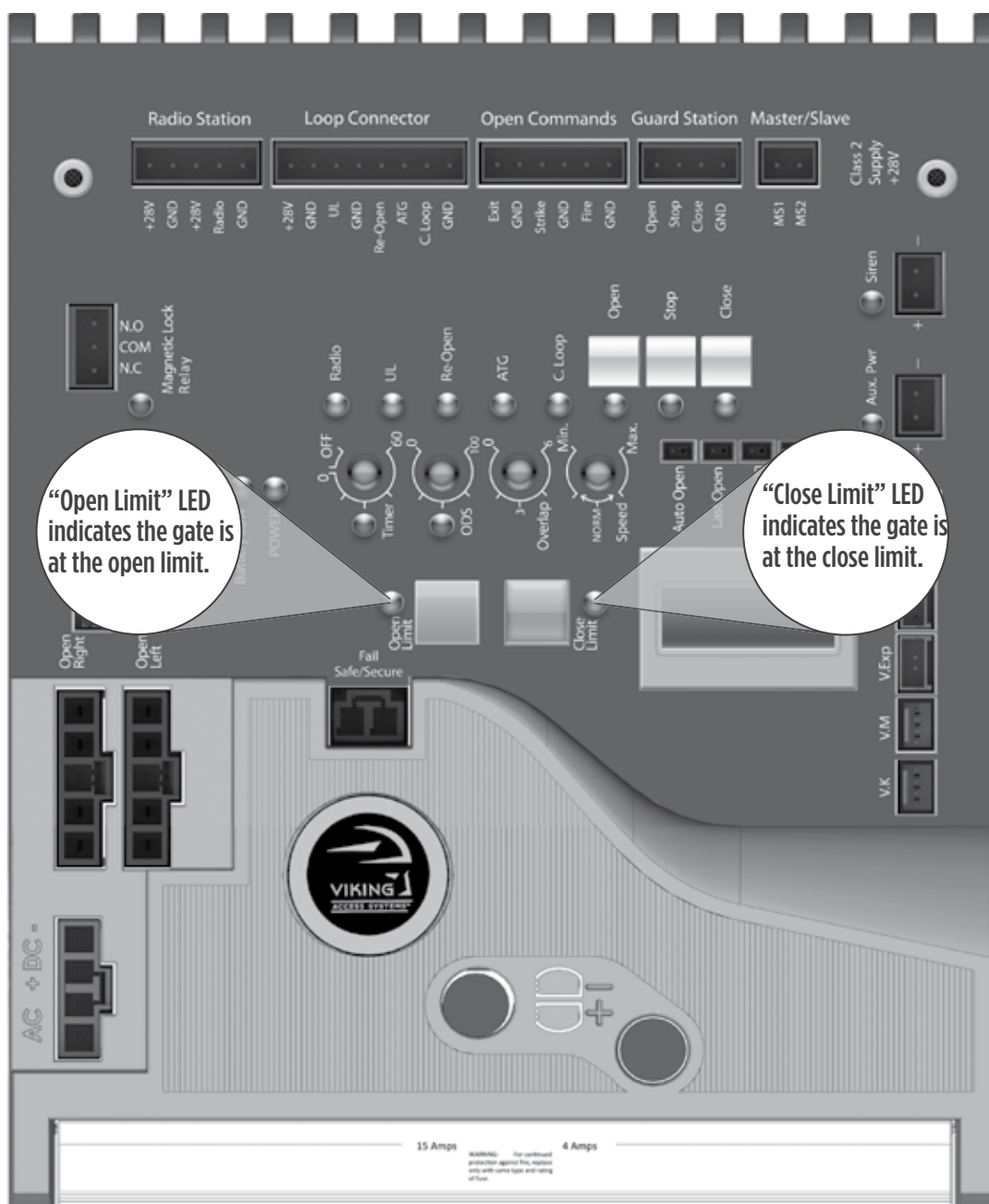

MASTER/SLAVE SETUP

Two Wire Communication

⚠ IMPORTANT: DO NOT run the Master/Slave communication cable in the same conduit or within 12" of 115 - 230V power supply cables.

⚠ Technical Tip: DO NOT set the "Timer" and/or "Overlap" features on both operators Control Boards. Only turn these features on at the Master Control Board.

Step 1

Connect shielded cable to "Master/Slave" connectors at the control boards

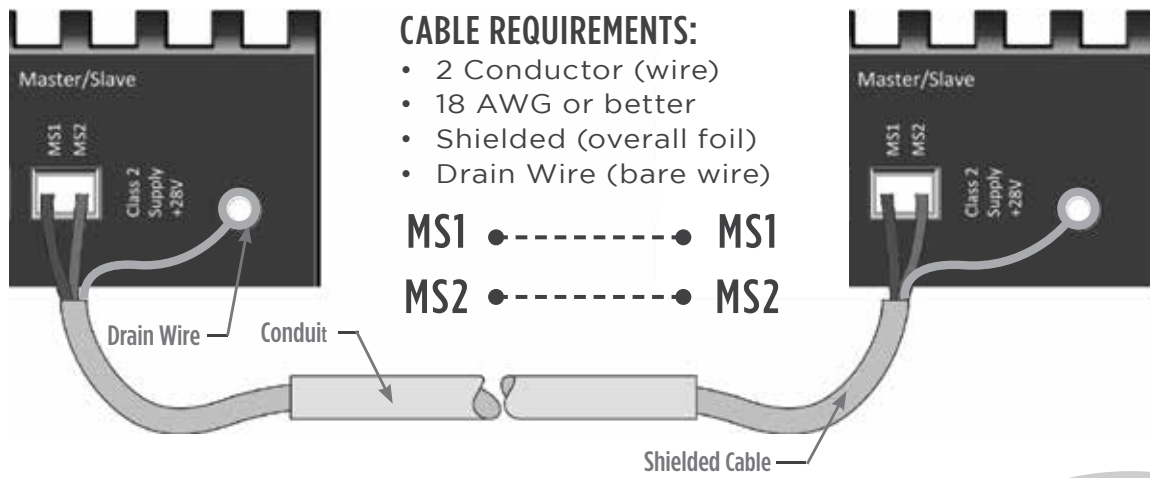

Step 2

At the Master Operator:

Connect the entrapment protection sensor(s) as described on page 11.

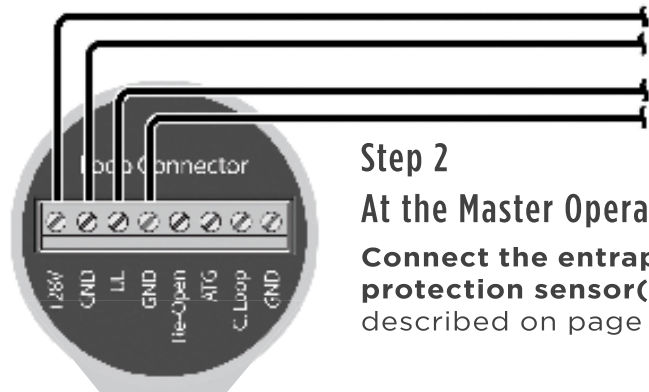

Step 3

At the Slave Operator:

Turn ON the SLAVE MODE Feature:

- Toggle the "Diagnose" button until you see SLAVE MODE on the LCD Display.
- Default setting is OFF.
- Press and hold the "Stop" button.
- Toggle the "Diagnose" button once.
- The feature should now be displayed as "ON".

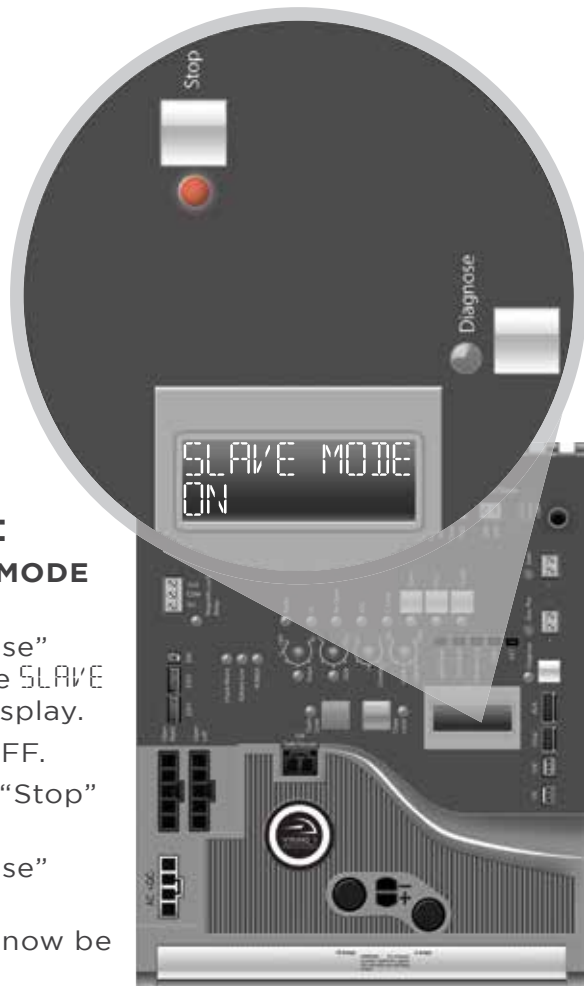

MASTER/SLAVE SETUP

Wireless Communication Options

⚠ **Technical Tip:** DO NOT set the “Timer” and/or “Overlap” features on both operators Control Boards. Only turn these features on at the Master Control Board.

REQUIRED ADD-ON:

Viking Konnect - Wireless Master/Slave Kit

PART# VA-KONNECT-MS

Step 1

Plug the modules on to the “V.K” plug & play connection of each operators Control Board. It is not important which board the master or slave module is placed on.

Step 2

At the Master Operator: Connect the secondary entrapment protection sensor(s) as described on pages 11 and 22.

Step 3

At the Slave Operator: Turn ON the SLAVE MODE Feature as described on page 22.

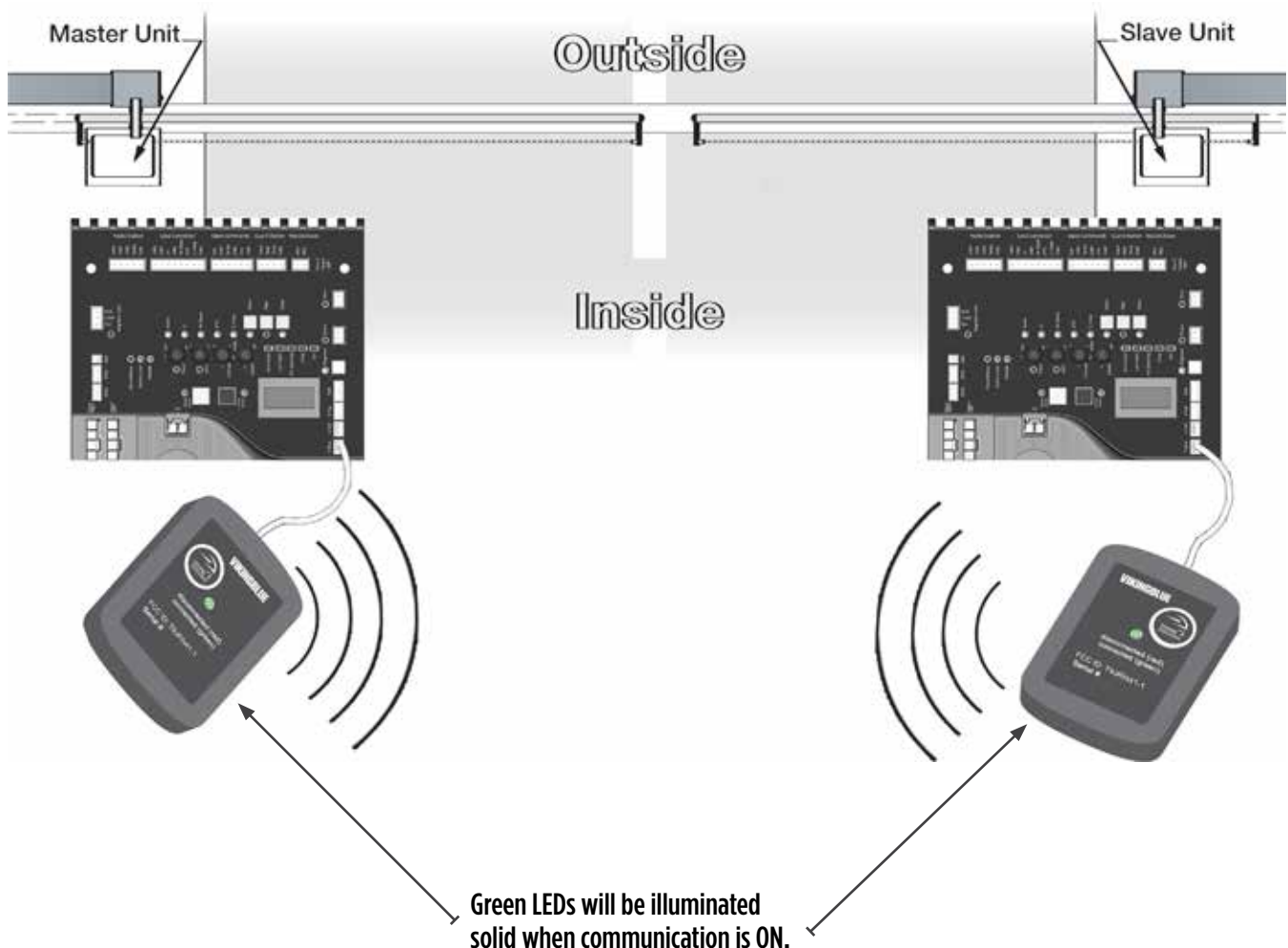

CONTROL BOARD SETUP

Initial Settings

“Timer” Hold Open Timer

Automatically closes the gate after the selected amount of time from 1-60 seconds.

Turning the dial between “0” and “OFF” will disable this feature, requiring a close command to close the gate.

“Overlap” Overlap Delay

For Master/Slave applications. The control board that has this feature turned on is the MASTER and will delay to open for 1-6 seconds. Slave will delay to close.

⚠ Do not turn this feature on at both control boards, only the Master.

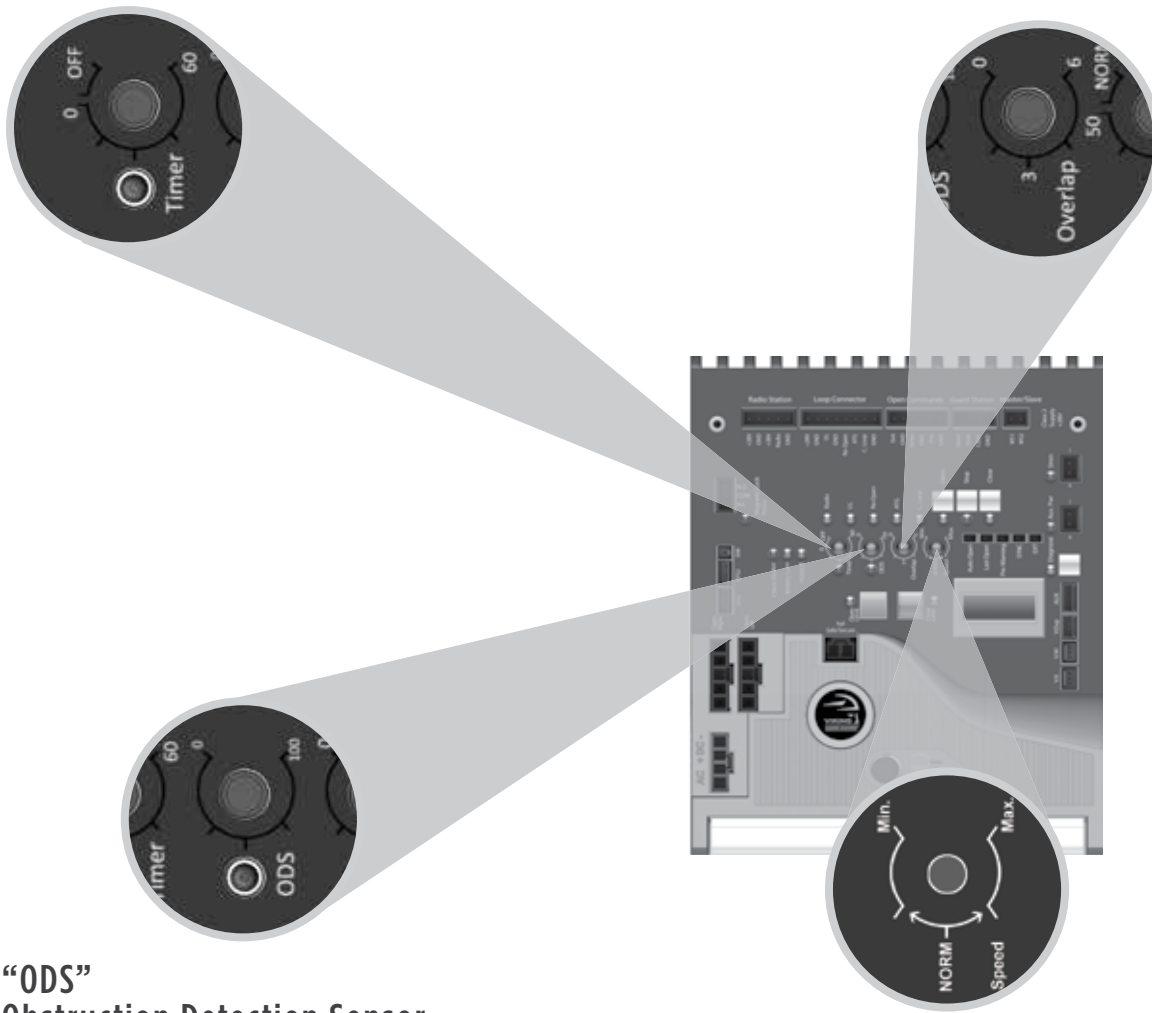

“ODS” Obstruction Detection Sensor

Sets the amount of force required to trip the inherent obstruction sensor.

See page 26 for more details about this feature.

“Speed” Motor Speed

Increases or decreases the speed of gate travel.

CONTROL BOARD SETUP

Initial Settings

NOTE: Installing a shunt or jumper on the pins will activate the feature.

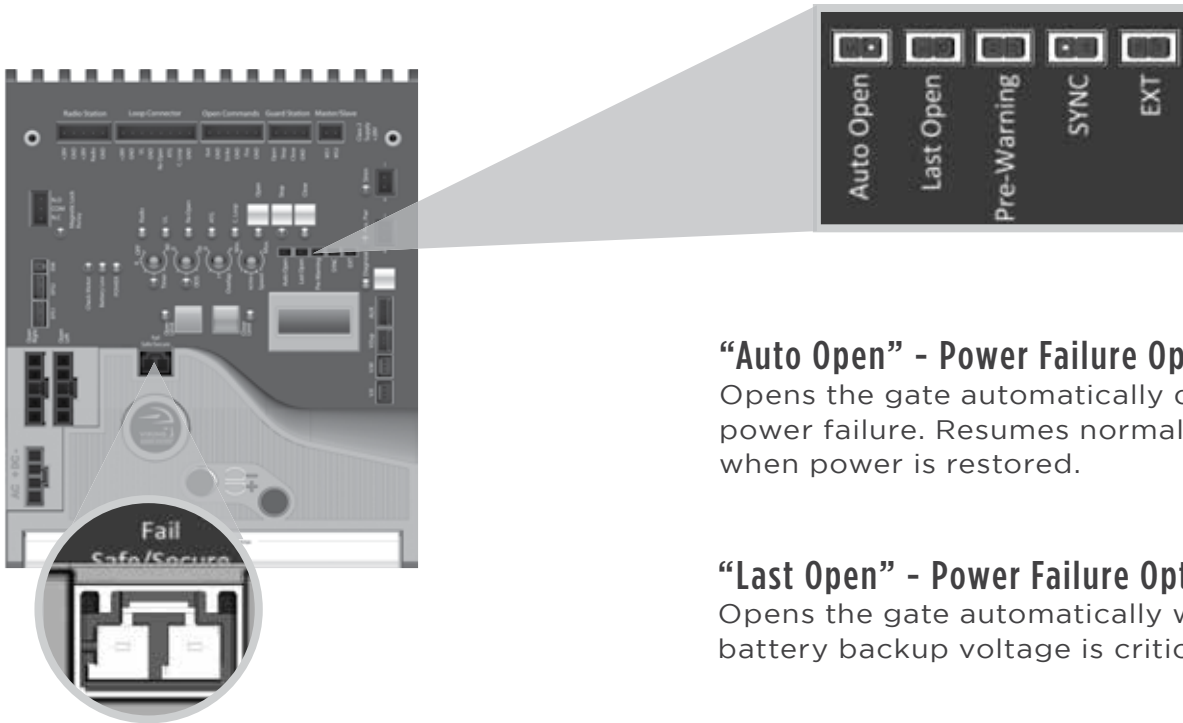

“Fail Safe/Secure”

During complete power failure, including battery power; determines the force required to manually move the gate.

- **Fail Safe Mode:**

By removing the wire-jumper plug from the “Fail Safe/Secure” connector:
The gate can move manually with a relatively low amount of force.

- **Fail Secure Mode:**

By inserting the wire-jumper plug into the “Fail Safe/Secure” connector:
The gate will not move manually.

“Auto Open” - Power Failure Option

Opens the gate automatically during power failure. Resumes normal operation when power is restored.

“Last Open” - Power Failure Option

Opens the gate automatically when the battery backup voltage is critically low.

“Pre-Warning” Initiates two options for an audio or visual warning 3 seconds prior to gate motion and will continue:

1. **Until gate reaches closed limit:**

“Magnetic Lock” terminals provide a contact between “COM” and “N.O.”.

2. **Until gate reaches either limit:**

“AUX. PWR” terminals provide 24VDC.

“Sync” Used only in conjunction with the Viking Barrier gate operator model B-12. Activating this feature allows for synchronized operation with the B-12 operator. See page 35.

“EXT” Available for future developments.

⚠ IMPORTANT: Regardless of the power failure options chosen, the gate can be moved manually with a relatively low amount of force by following the steps for “Manual Release” as outlined at on page 11.

CONTROL BOARD SETUP

Obstruction Detection Sensor (ODS)

⚠ IMPORTANT: The appropriate “ODS” setting is dependant upon the gate installation and construction. Set this feature accordingly. Additional Safety equipment should be used to reduce possible risk of injury or vehicle damage.

“ODS” Obstruction Detection Sensor

The Obstruction Sensor detects obstructions in the path of the traveling gate. The dial sets the amount of force required to activate the operators inherent obstruction detection.

Setting the dial to “0” will require the least amount of force to activate;

Setting the dial to “100” will require the maximum amount of force to activate.

UL325 standard requires an audio alarm to go off after two consecutive entrapment events sensed by the Inherent Entrapment Protection of the Gate Operator.

The audio alarm will sound for a period of 5 minutes or until a Stop command or the “Alarm Reset” switch has been actuated. (refer to page 12)

When the Obstruction Sensor detects an obstruction it will:

1. Stop the gate’s movement and reverse it momentarily.
2. Bring the gate to a resting position.
3. Disable the Hold Open Timer feature until the Gate Operator receives a new command.

If second obstruction is detected before the gate reaches either limit it will:

1. Stop the gate’s movement.
2. Disable the Gate Operator.
3. Sound the UL Alarm
4. A STOP command must be provided to disable the alarm and continue operation.

⚠ TECHNICAL TIP: The Status LED for the “ODS” will indicate the following when it has been triggered.

- A. Solid:** Obstruction. Detected a sudden or abrupt increase in gate resistance.
- B. Flashing:** Overload. Detected a more subtle, but sustained increase in gate resistance.

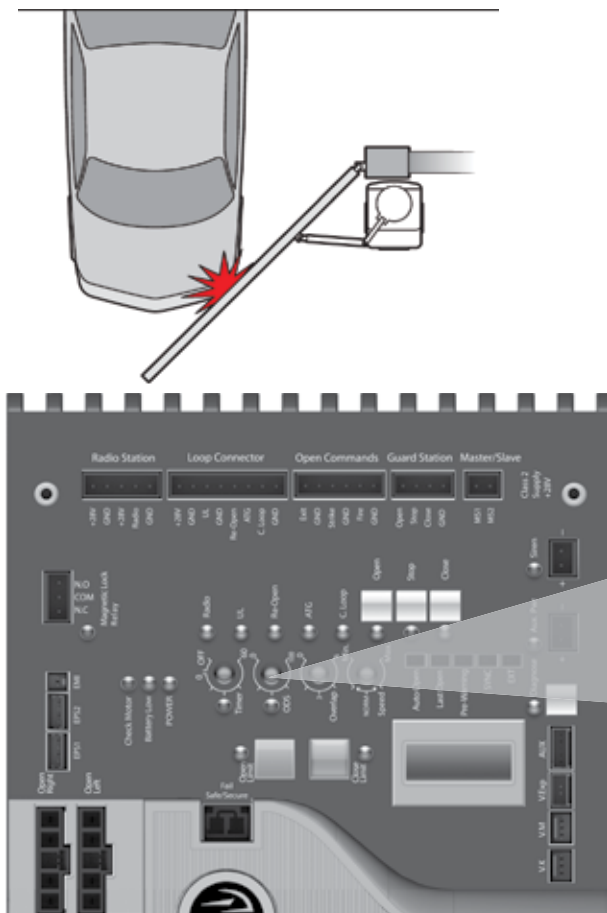

CONTROL BOARD SETUP

Viking Heater

The operator has an integrated heater that is thermostatically controlled. Activate this feature when the operator is used in application temperatures down to -20°F (-29°C).

To set the heater to turn on at the Close Limit:

1. Use the “Diagnose” button to scroll through the LCD Display to “HEATER CLS
2. Press and hold the “Stop” button on the control board.
3. Press and release the “Diagnose” button to turn this feature ON and OFF.

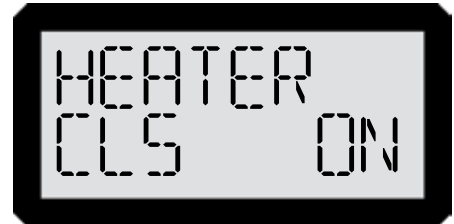

To set the heater to turn on at the Open Limit:

1. Use the “Diagnose” button to scroll through the LCD Display to “HEATER OPN
2. Perform steps 2-3 as described above.

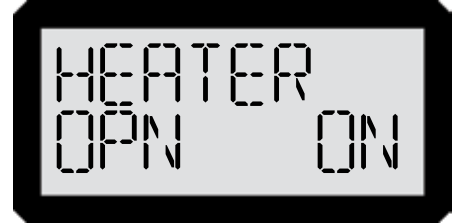

NOTE: If the application requires the gate to be held open for any reason, set the HEATER ON for both limit positions.

⚠ IMPORTANT: A POSITIVE STOP **must** be used on the gate at the limit position(s) the HEATER has been set for.

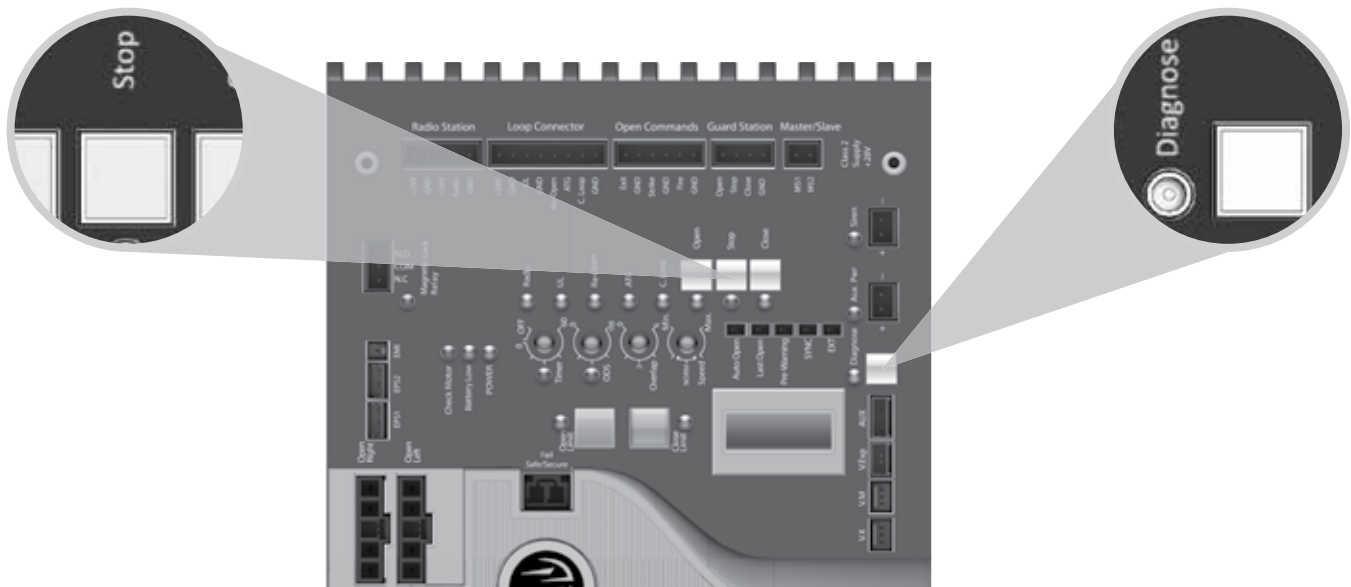

Viking Lock Mode

Turning this feature ON will secure the gate at the closed position, preventing unauthorized manual entry.

Use the LCD Display to activate this feature.

1. Use the “Diagnose” button to scroll through the LCD menu to “LOCK MOD
2. Press and hold the “Stop” button on the control board.
3. Press and release the “Diagnose” button to turn this feature ON and OFF.



ACCESSORY CONNECTIONS

⚠ Cable use in Class 2 circuit to an external device shall be type CL2, CL2P, CL2R, CL2X or other cable with equivalent or better electrical, mechanical, and flammability ratings.

UL (Monitored Input Terminal)

The “UL” input terminal protects against entrapment in both the opening and closing directions. Input will reverse the gate momentarily in the opposite direction it was traveling when a connected device it triggered. see pages 10-11.

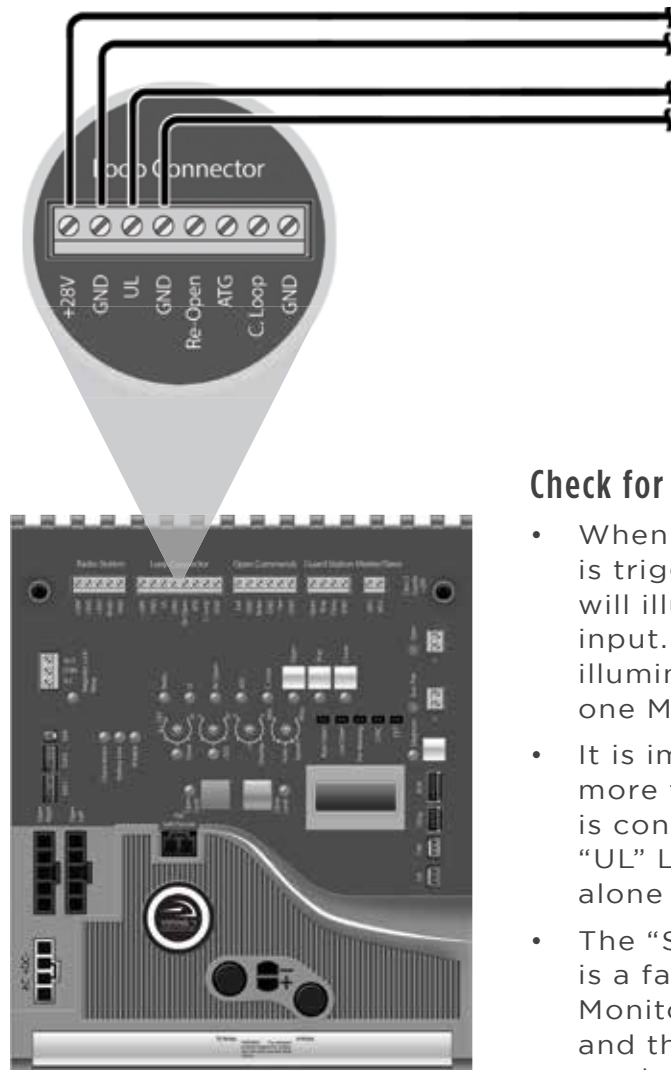

Check for proper operation:

- When a connected device is triggered, the “UL” LED will illuminate to indicate an input. The “Stop” LED will also illuminate if there is more than one Monitored device connected.
- It is important to note that if more than one Monitored device is connected to this terminal, the “UL” LED will be illuminated. This alone is inconsequential.
- The “Stop” LED will flash if there is a failure with at least one Monitored entrapment sensor and the gate operator will be rendered inoperable.

⚠ **TECHNICAL TIP:** For more information regarding accessory connections to the control board and individual input terminal functions, refer to “Appendix (A)” pages 42-43.

ACCESSORY CONNECTIONS

⚠ Cable use in Class 2 circuit to an external device shall be type CL2, CL2P, CL2R, CL2X or other cable with equivalent or better electrical, mechanical, and flammability ratings.

Re-Open (Monitored Input Terminal)

The “Re-Open” input terminal protects against entrapment in the closing direction ONLY. Input will reverse the gate all the way to the Open Limit when a connected device is triggered. see pages 10-11.

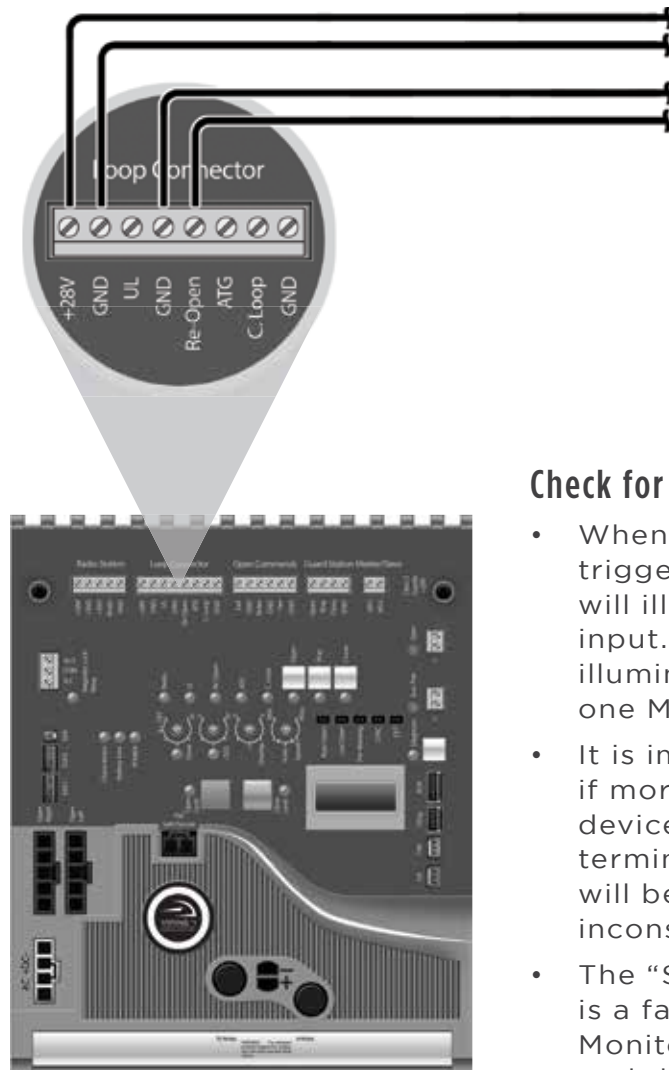

Check for proper operation:

- When a connected device is triggered, the “Re-Open” LED will illuminate to indicate an input. The “Stop” LED will also illuminate if there is more than one Monitored device connected.
- It is important to note that if more than one Monitored device is connected to this terminal, the “Re-Open” LED will be illuminated. This alone is inconsequential.
- The “Stop” LED will flash if there is a failure with at least one Monitored entrapment sensor and the gate operator will be rendered inoperable.

⚠ TECHNICAL TIP: For more information regarding accessory connections to the control board and individual input terminal functions, refer to “Appendix (A)” pages 42-43.

ACCESSORY CONNECTIONS

⚠ Cable use in Class 2 circuit to an external device shall be type CL2, CL2P, CL2R, CL2X or other cable with equivalent or better electrical, mechanical, and flammability ratings.

Radio Receiver (Typical)

⚠ **IMPORTANT:** The Hold Open “Timer” setting (page 24) affects how the gate will respond to the radio receiver command.

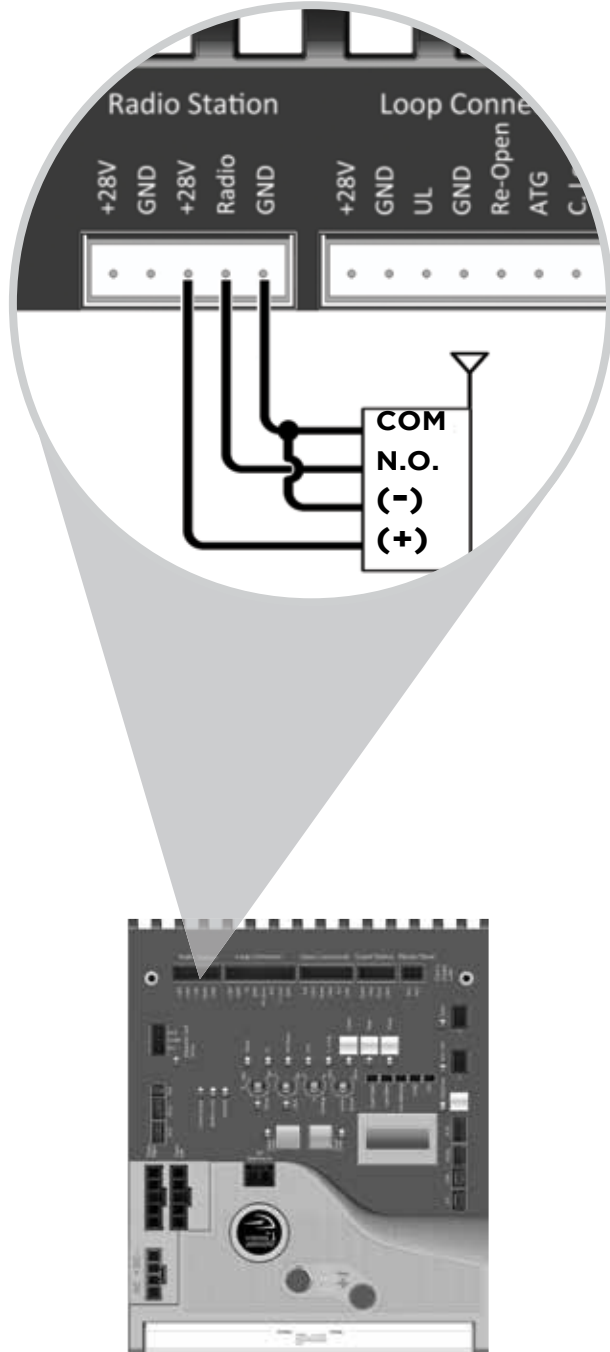

The control board provides two modes of operation that a radio receiver can control the gate:

Open-Stop-Close

1. By having the radio receiver connected as illustrated and with the Hold Open Timer OFF (see page 24):

Every command of the radio transmitter will control the gate as follows:

- First command opens the gate,
- Second command stops the gate and
- Third command closes the gate
- Any subsequent commands will continue in the same order to control the gate.

This type of configuration is not recommended for commercial installations.

Open Only

2. By having the radio receiver connected as illustrated and with the Hold Open Timer ON (see page 24):

Each command of the radio transmitter is **ALWAYS AN OPEN COMMAND** to the gate.

For maximum reception range:

Locate the radio antenna to the top of the gate column.

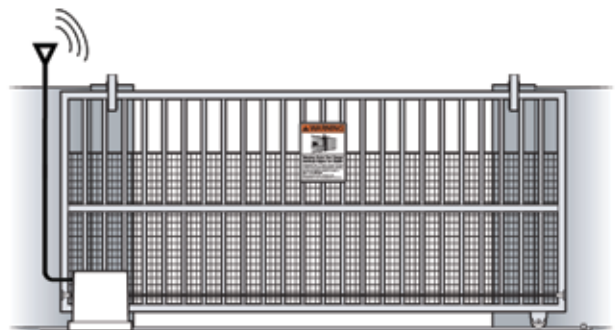

⚠ **TECHNICAL TIP:** For more information regarding accessory connections and terminal functions, refer to “Appendix (A)” on pages 42-43.

See “Appendix (B)” on page 44 for connecting common radio receiver models.

ACCESSORY CONNECTIONS

⚠ Cable use in Class 2 circuit to an external device shall be type CL2, CL2P, CL2R, CL2X or other cable with equivalent or better electrical, mechanical, and flammability ratings.

Anti-Tailgate, Open Commands & Guard Station

⚠ TECHNICAL TIP: For more information regarding accessory connections and terminal functions, refer to “Appendix (A)” on pages 42-43.

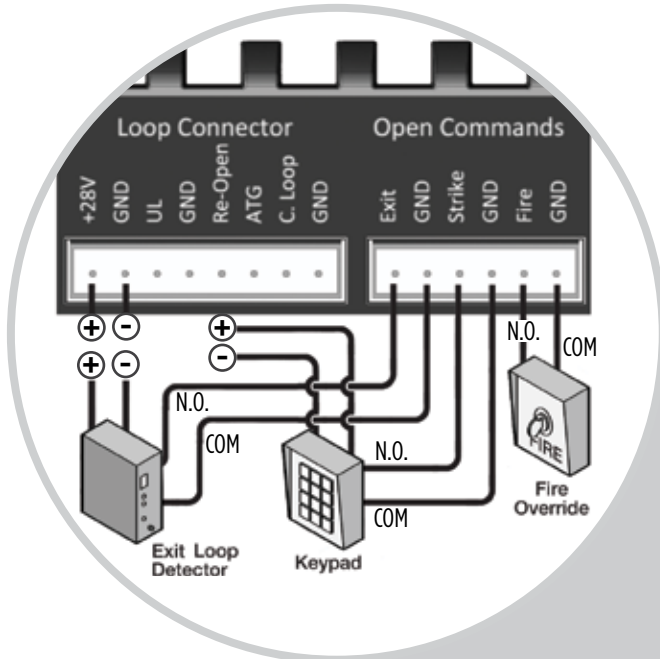

Open Commands

“Exit”, “Fire” and “Strike” input terminals all provide an open command to the control board. Any device connected as shown will open the gate.

Guard Station

⚠ All three buttons must be a Normally Open “N.O.” type of switch, and can share the same common “C” connection to “GND”.

“ATG” Anti-Tailgate

This input will stop the gate when the vehicle triggers the sensor, then closes the gate when the vehicle leaves the sensor, preventing unauthorized vehicles from entry.

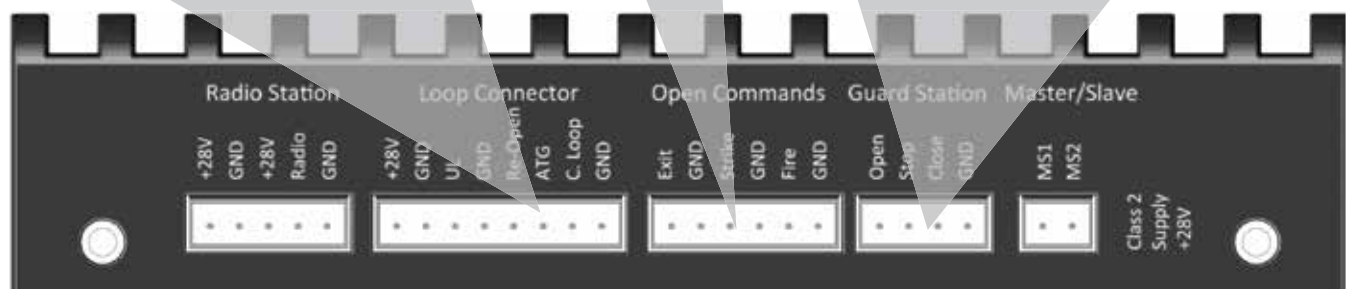
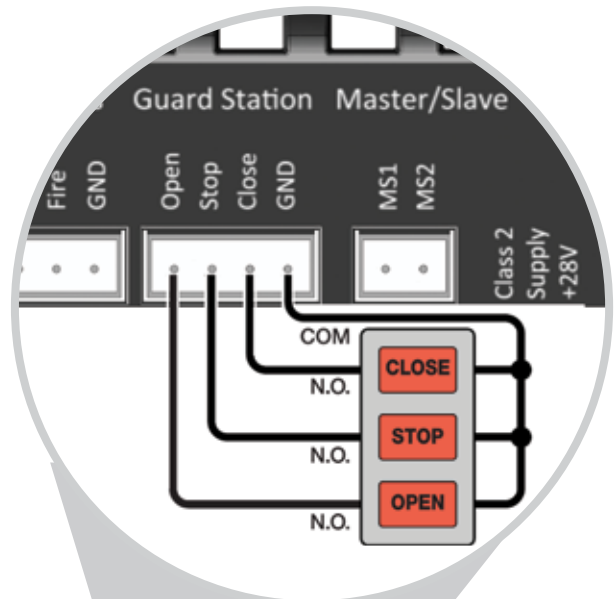
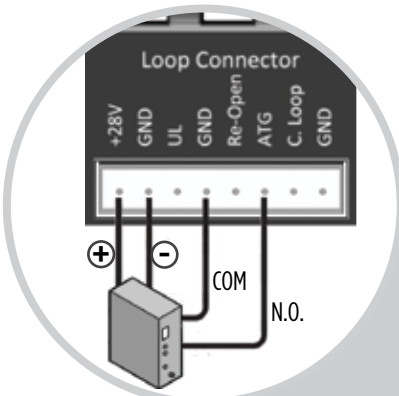

ACCESSORY CONNECTIONS

Viking Loop Rack

TIP: This operator may be equipped with a pre-wired **Loop Rack** that plug-in type loop detectors can be connected to. This provides a convenient alternative to the box type loop detectors that would need to be wired to the control board. Viking does not provide either type of loop detectors.

Loop Rack: Part # VA-LR

Loop Rack Wiring Harness: Part # VA-LRH

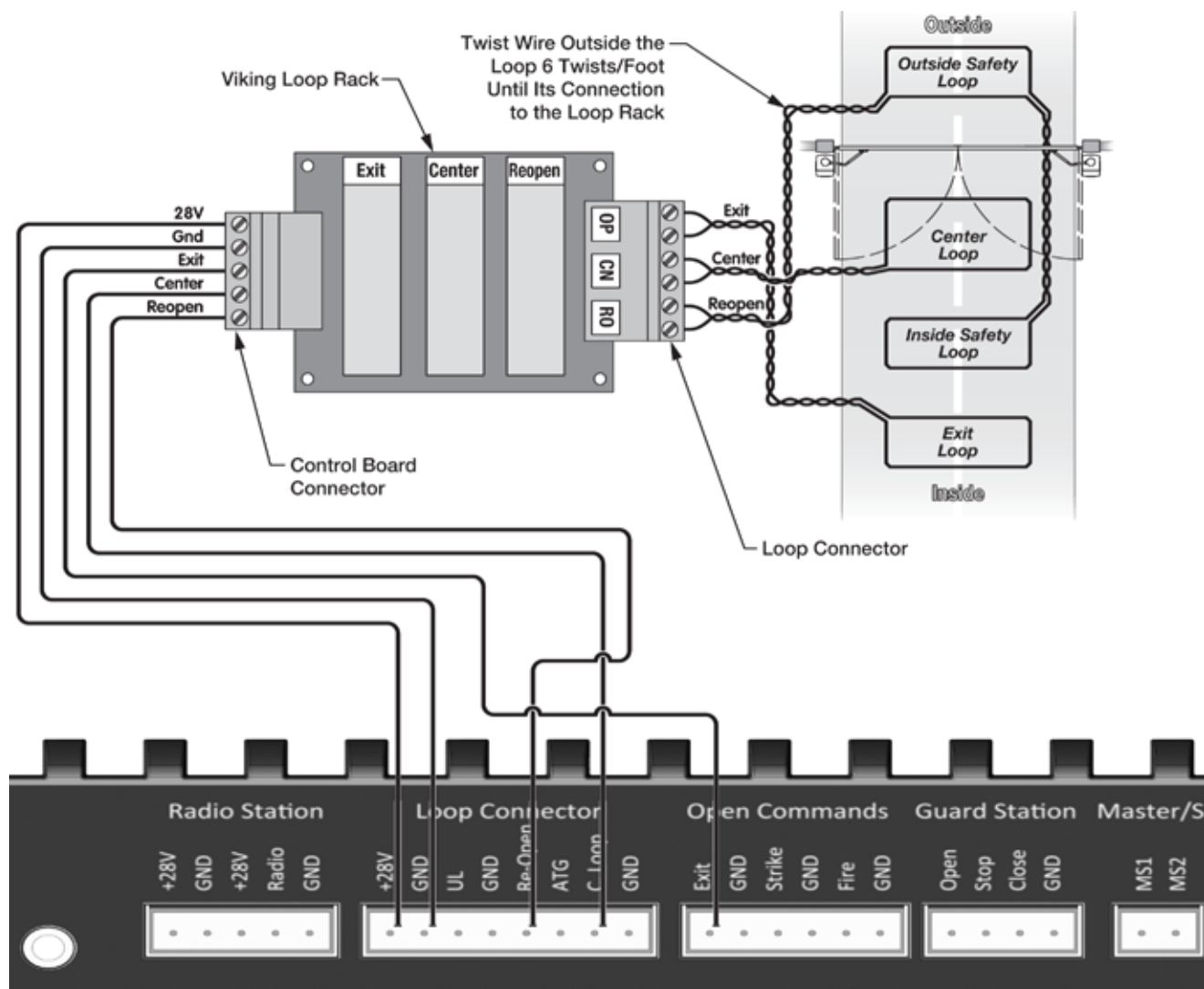

ACCESSORY CONNECTIONS

Guidelines for Loop Installation

1. Prevent sharp corners in the geometry of the loop sensor.
2. Install the appropriate number of turns for your loop geometry based on the loop perimeter. Use Table C (below) as a guide.
3. Use XLP (cross-linked-polyethylene) type of wire. This wire reduces the effects of moisture and other environmental events in altering the functionality of the vehicular loop detector.
4. Twist the lead wire at least 6 turns per foot.
5. Use BACKER-ROD to minimize damage to the loop detector wire prior to using the sealant.
6. Place the loop detector wire and adjust the sensitivity of the vehicular loop detector unit in a way to minimize the effects of the gate over the loop detector wire.

⚠ IMPORTANT! Some of the following parameters may affect the proper functionality of the vehicular loop detector.

Consult the manufacturer of the vehicular loop detector and/or loop wire.

- Gate size
- Number of turns in the loop sensor wire
- Distance of the loop sensor wire to the gate at either at the open or close position

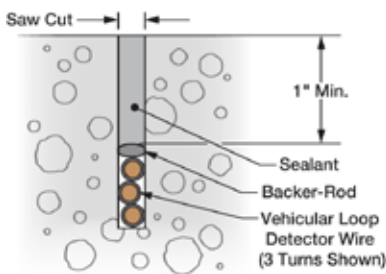
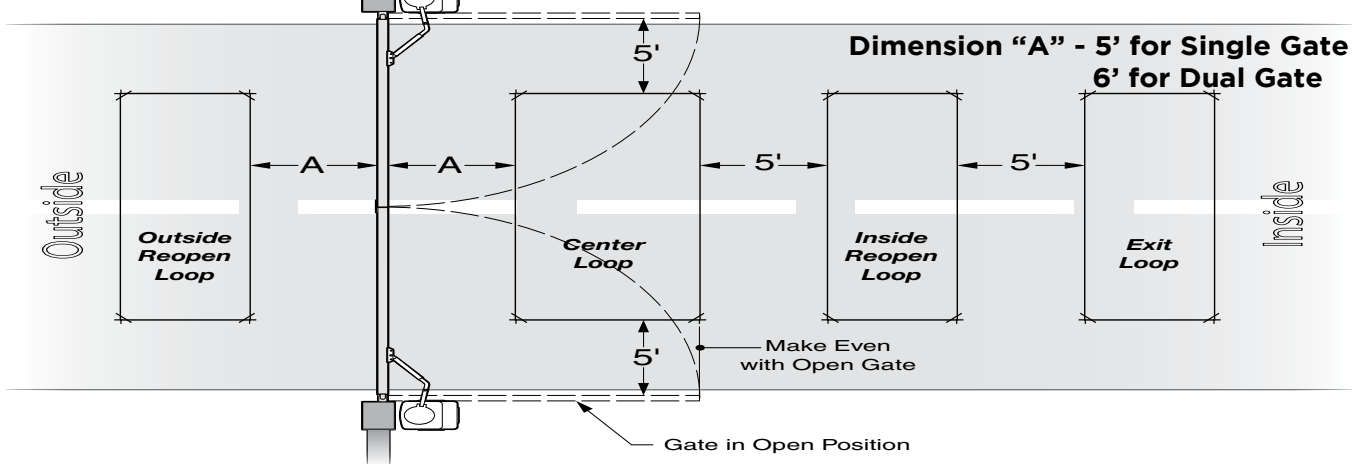
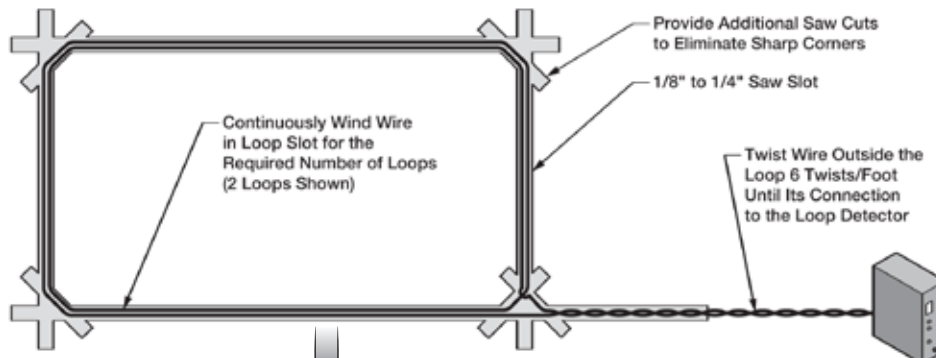

Table C - Recommended Number of Turns

Perimeter (ft.)	Number of Turns
10	5
20	4
30-40	3
50-100	2



ACCESSORY CONNECTIONS

Magnetic Lock, Lock Solenoid

NOTE: Viking Access Systems does not provide external gate lock devices. These items can be purchased from your dealer or distributor.

Magnetic Lock

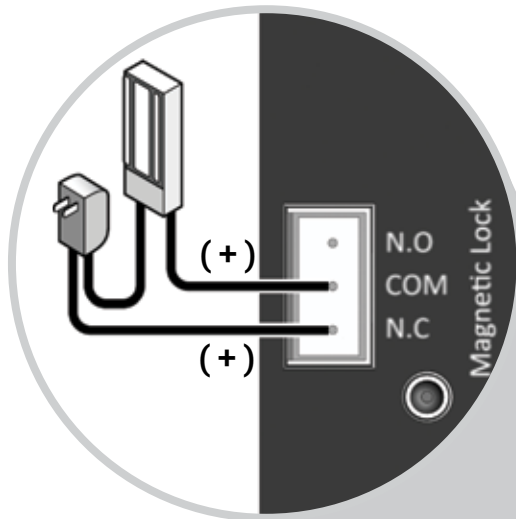

Lock Solenoid

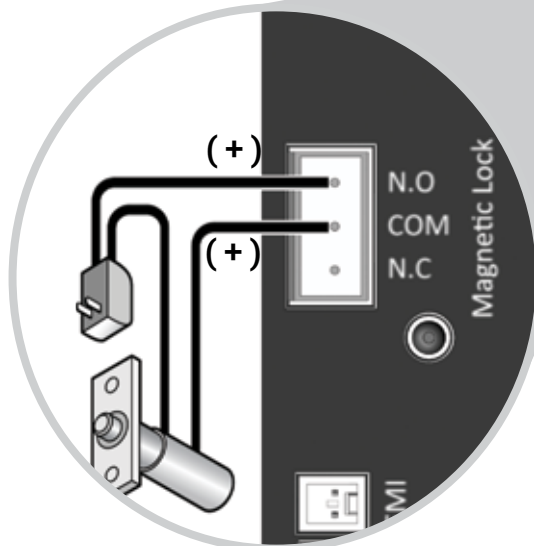

Power for the Locks:

Do not use the 24VDC power supplied by the control board. An external power supply, or plug-in transformer, must be used for the magnetic lock or lock solenoid. Plug the transformer into the “120VAC” receptacle provided at the operators Power Box. This will prevent rapid drainage of the battery in the event of power failure.

The control boards “Magnetic Lock” relay is rated for 10A-250VAC.

⚠ TECHNICAL TIP: The Magnetic Lock Relay LED will indicate status of the on-board relay even if a lock is not connected to the control board. Refer to page 36.

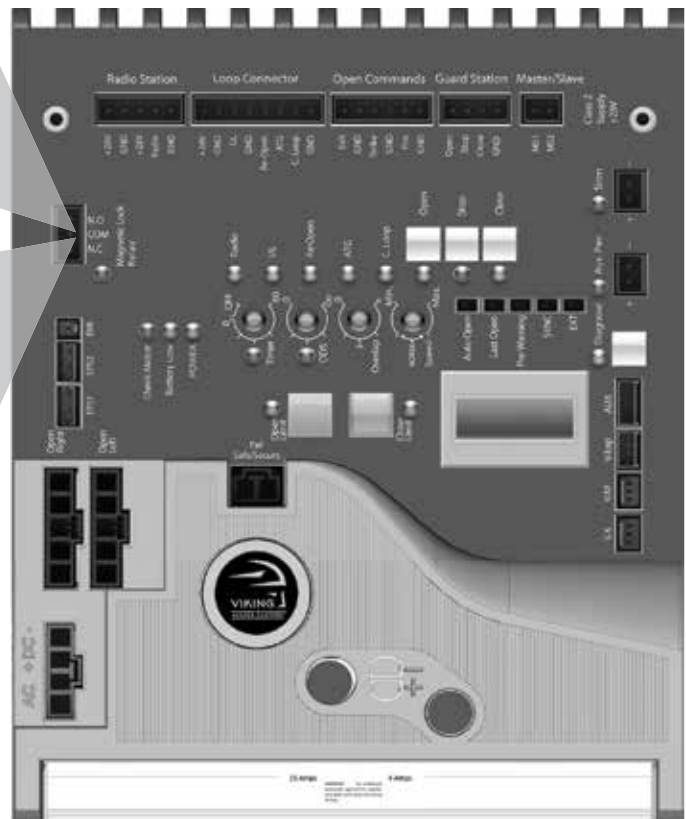

ACCESSORY CONNECTIONS

Barrier Arm Synchronization

NOTE: The Control Board provides a convenient solution for applications that require synchronized operation with the Barrier Arm Operator.

This type of application opens and closes in the following pattern:

1. Open Command is provided only to the Barrier Arm operator.
2. The Barrier Arm will send an open input to the Viking gate operator; Barrier Arm will delay to open until the Viking gate operator reaches its Open Limit.
3. Barrier Arm will close first; the Viking gate operator will delay to close until the Barrier Arm reaches its Close Limit.

STEP 1 (Figure A)

At the Barrier Arm operator, connect the device(s) that will be used as the primary OPEN input.

STEP 2 (Figure A & B)

Connect the Barrier Arms' designated sync output terminals to the Strike input at the Viking gate operator.

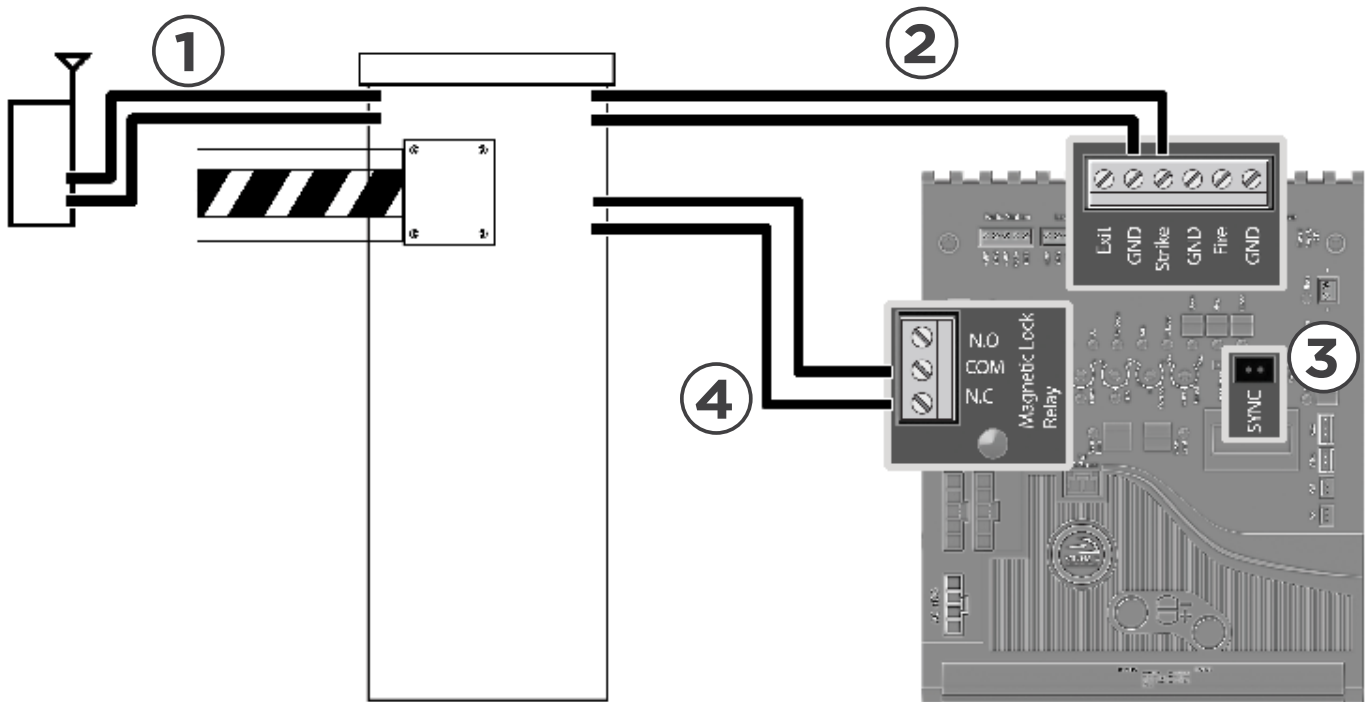

STEP 3

At the Viking gate operator, activate Sync Mode by placing a jumper on to the pin headers labeled "SYNC".

STEP 4

Connect Magnetic Lock relay terminals ("COM" and "N.C.") to the Barrier Arms' designated sync input terminals.

TROUBLESHOOTING

LED References

In addition to the LCD Display, the control board LEDs monitor the various circuits of the control board. Use the table below to identify the corresponding “TS Ref#” and refer to page 38-41 for further troubleshooting.

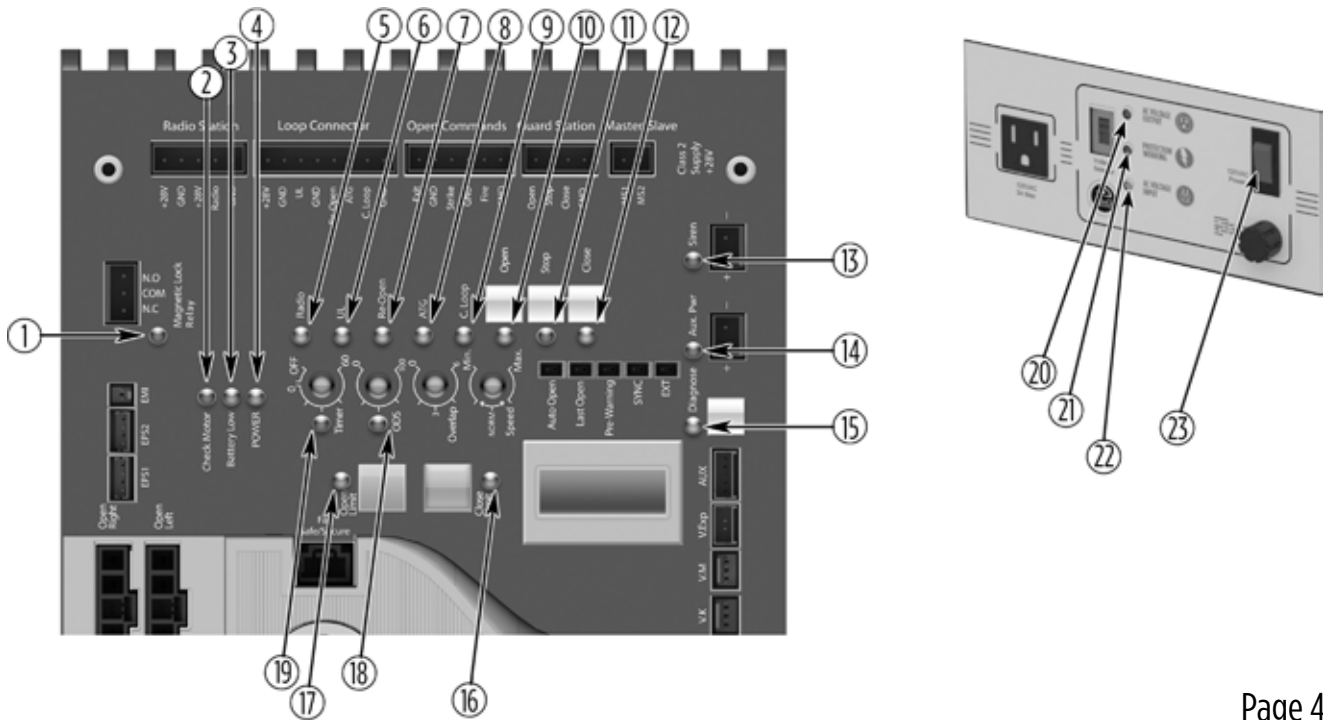

#	LED	Status	Meaning	TS Ref#(s)
1	"Magnetic Lock Relay"	OFF	At Closed Limit and Magnetic Lock Relay state is closed across "COM" & "N.C.". (pg 34). Gate should be at the Close Limit.	
		SOLID	Not at Closed Limit and Magnetic Lock Relay state is closed across "COM" & "N.O.". (pg 34). Gate should not be at the Close Limit	
2	"Check Motor"	OFF	Normal Condition.	
		SOLID	The control board is sending power to the motor but the circuit is open.	7, 8
3	"Battery Low"	OFF	Normal Condition.	
		SOLID	Batteries are low. Check power supply to the operator. (pg 18-19).	1, 2
		FLASHING	Batteries critically low. Check power supply to the operator. (pg 18-19).	1, 2
4	"POWER"	SOLID	Normal Condition.	
		FLASHING	Operator is running on batteries only (pg 18-19).	1, 2
		OFF	No power to control board.	1, 2, 4, 5
5	"Radio"	OFF	Normal Condition.	
		SOLID	Control Board is receiving an input from a device connected to the Radio terminal (pg 30, 42).	9, 10
6	"UL"	OFF	Normal Condition.	
		SOLID	Control Board is receiving an input from a device connected to the UL terminal or when more than one device is connected (pg 10-11, 28, 42).	9, 10, 16, 22
7	"Re-Open"	OFF	Normal Condition.	
		SOLID	Control Board is receiving an input from a device connected to the Re-Open terminal or when more than one device is connected (pg 10-11, 29, 32, 42).	9, 10, 16, 22
8	"ATG"	OFF	Normal Condition.	
		SOLID	Control Board is receiving an input from a device connected to the ATG terminal (pg 31, 42).	9, 10

TROUBLESHOOTING

LED References

Use the table below to identify the corresponding “TS Ref#” and refer to page 38-41 for further troubleshooting.

Pg 41

#	LED	Status	Meaning	TS Ref#(s)
9	“C Loop”	OFF	Normal Condition.	9, 10
		SOLID	Control Board is receiving an input from a device connected to the C Loop terminal (pg 32, 42).	
10	“Open”	OFF	Normal Condition.	9, 10
		SOLID	Control board is receiving an input from a device connected to any of the following input terminals: Exit, Fire, Strike or Open (pg 31, 42).	
11	“STOP”	OFF	Normal Condition.	9, 10
		SOLID	Control Board is receiving an input from a device connected to the Stop, UL or Re-Open terminals (pg 28-29 31, 42).	
		FLASHING	There is a problem with the required monitored sensor(s) connected to the “UL” and/or “Re-Open” input terminals (pg 10-11, 22 and 28-29)	
12	“Close”	OFF	Normal Condition.	9, 10
		SOLID	Control Board is receiving an input from a device connected to the Close terminal (pg 31, 42).	
13	“Siren”	OFF	Normal Condition.	11, 13, 1, 2
		SOLID	Second consecutive obstruction has been detected. (pg 26).	
		FLASHING	Batteries are critically low.	
14	“Aux. Pwr”	OFF	No voltage output on these terminals at the moment.	1, 2
		SOLID	There is 24VDC output on these terminals at the moment.	
15	“Diagnose”	OFF	Normal Condition.	6
		FLASHING	Errors have been detected; Check LCD Display for ERR messages (pg 40).	
16	“Close Limit”	OFF	Gate is not at the close limit position.	6
		SOLID	Gate is at the close limit position.	
		FLASHING	Close limit position has been erased or not set (pg 20-21).	
17	“Open Limit”	OFF	Gate is not at the open limit position.	6
		SOLID	Gate is at the open limit position.	
		FLASHING	Open limit position has been erased or not set (pg 20-21).	
18	“ODS”	OFF	Normal Condition.	11, 13, 1, 2
		SOLID	Obstruction has been detected. (pg 26).	
		FLASHING	Overload has been detected. (pg 26).	
19	“Timer”	OFF	The close timer is turned OFF or gate is not at the open limit if the timer is turned ON. (pg 24).	9, 10
		SOLID	Gate is at Open Limit, Timer is turned ON and counting down to close. (pg 24).	
		FLASHING	Gate is at Open Limit, Timer is turned ON but is not timing out due to a conflicting command. (pg 24).	
20	“AC VOLTAGE INPUT”	SOLID	Normal Condition.	1
		OFF	Incoming power to Power Supply Panel Assembly is not sufficient.(pg 18).	
21	“PROTECTION WORKING”	SOLID	Normal Condition.	2
		OFF	EMI Board is damaged and circuit is not protected . Replace EMI Board.	
22	“AC VOLTAGE OUTPUT”	SOLID	Normal Condition.	2
		OFF	There is no output voltage from the Power Supply Panel Assembly.	
23	“AC POWER”	SOLID	Normal Condition for High Voltage installations.	1
		OFF	High Voltage is not supplied to the Modular Power Box (pg 18).	

TROUBLESHOOTING

LCD Display References

The control board is equipped with a LCD Display that provides operator information, current conditions, settings, diagnostics and error messages. Use the table below to identify the corresponding “TS Ref#” and refer to page 41 for further troubleshooting.

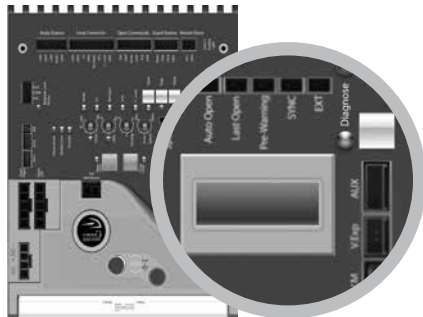

1. Error Messages will be displayed first.
2. The "Diagnose" LED will flash consecutively indicating how many Error Messages are available.
3. Press the Diagnose button to manually scroll through all of the Messages.

Page 41
TS Ref #s

LCD MSG	Meaning	
VIKING ACCESS	Welcome Message	
MODEL F1	Indicates the Model of the unit	
System Status Messages		
GATE IS IDLE	Gate is stopped between limits	
GATE IS OPENING	Gate is opening	
GATE IS CLOSING	Gate is closing	
GATE IS OPENED	Gate is at the limit open position	
GATE IS CLOSED	Gate is at the limit close position	
STOP BY OBSTRUCT	Gate stopped due to an obstruction sensor event	11, 12, 13, 22
STOP BY OVERLOAD	Gate stopped due to an overload of the gate system	11, 12
OVERLAP TIMING	Gate is waiting for the overlap time	
HOLDING ... SEC	Gate is at the limit open position and timing to close - The display shows the actual time left before closing	
UL LEARN UL_ RO_	Indicates the number of connected Monitored Entrapment Protection Sensors that are being monitored. NO LEARN = no sensors learned. (pg 11)	

LCD Display References

LCD MSG Meaning

Multi Meter Displays

MOT AMP ---- A	This is the motor current amperage during operation
MOT VOLT ---- VDC	This is the actual motor voltage during operation
AC VOLT ---- VAC	This is the actual low voltage AC to the Control Board from the transformer
CHARGE ---- VDC	Indicates the charging voltage to the batteries, if the Battery Switch is in the OFF position.
BAT VOLT ---- VDC	Indicates battery voltage, if the AC power is discontinued to the Control Board.

Board Settings Messages

SPEED __%	Shows the percentage of speed set by the Speed adjustment on the control board. (pg 24)
OVERLAP __ SEC	Shows the number of seconds set by the Overlap Adjustment on the control board. This feature is not available on slide gate operator models
ODS SENS ----%	Shows the force setting selected to trip the obstruction sensor. (pg 26)
TIMER __ SEC	Shows the amount time set or remaining to hold the gate at the Open Limit position, before the gate starts to close. (pg 24)
HEATER __ OFF	The Integrated Heater is disabled for the open "OPN" and/or close "CLS" limits (pg 27)
HEATER __ ON	The Integrated Heater has been enabled to turn on at the open "OPN" and/or close "CLS" limits (pg 27) "*" will be displayed while it is heating
LOCK MOD OFF	The Lock Mode feature is turned OFF (pg 27)
LOCK MOD ON	The Lock Mode feature is turned ON (pg 27)

TROUBLESHOOTING

LCD Display References

Page 37
TS Ref #s

LCD MSG	Meaning	
Error Messages		
ERR AC LOW	Indicates that the 24VAC supply to the VFlex Board is too low from the 115/230 power supply.	1, 3, 20
ERR AC HIGH	Indicates that the 24VAC supply to the VFlex Board is too high from the 115/230 power supply.	1, 3, 20
ERR AC NO AC	Indicates that there is no 24VAC supply detected to the VFlex Board from the 115/230 power supply.	1, 2, 4, 20
ERR CHRG HIGH	Potential problem with the charging voltage from the control board.	1, ?
ERR CHRG CHECK 4A	a) 4 Amp Fuse is blown, or; b) There is a problem with the batteries or the control board.	18, ?
ERR BAT LOW	The battery is low.	1, 2, 3, 4
ERR FUSE 15 AMP	15 Amp motor fuse is blown on the Master or Single Control Board.	7, 11, 12
ERR EMI NO EMI	No EMI board detected.	15
ERR EMI NO FUSE	4 Amp main fuse is blown on Power Supply Panel Assembly.	2
ERR EMI NO AC	There is no AC voltage detected from the EMI Board.	20
ERR EMI UNKNOWN	There is a problem with the communication between the EMI Board and the VFlex Board.	21
ERR EMI PROTECT	Lightning strike protection for the EMI Board (behind the Power Supply Panel Assembly) needs to be replaced.	?
ERR SENS UL RO	There is a problem with the required monitored sensor(s) connected to the "UL" and/or "Re-Open" input terminals (pg 10-11, 22, 28-29).	22

TROUBLESHOOTING

Solutions

Begin the troubleshooting process by referring to the error messages on the LCD Display and/or the Status LEDs on the control board. Use pages 36-40 to identify the Troubleshooting Reference # (TS Ref#) then reference the table below.

TS Ref#	CHECK	Page Ref#
1	Check that the high voltage power supplied to “EMI Board” is within range. 100V-120V or 200V-240V.	pg 18
2	Remove and check EMI Fuse for continuity.	pg 3, 18
3	Check that the “Voltage Selector”, on the EMI Board, is set according to the high voltage power supply. 115VAC or 230VAC.	pg 3, 18
4	Check that the “AC POWER” switch is turned ON.	pg 3, 18, 36, 37
5	Check that the Power Harness is connected to the control board.	pg 4, 18
6	Check that the limit circuits are Normally Closed (N.C.). Check the limit switch.	pg 20-21
7	Check Motor Fuse on the control board.	pg 4
8	Check that the operator is not in Manual Release mode.	pg 3, 11
9	Check the Status LEDs and LCD Display to determine if the control board is receiving an input from any external devices or if the “ODS” has been triggered.	pg 24, 26, 36-38
10	Remove the external devices from the control board to determine if the control board is responding to an input or problem with the external device or wiring.	pg 28-32, 36-37
11	Check the “ODS” setting on the control board.	pg 8, 12, 26
12	Check that the gate can be moved manually with low resistance throughout its full range of motion.	pg 8, 17
13	Check the limit position.	pg 20-21
14	Not applicable to this model.	pg 4
15	Check that the EMI cable is properly connected to the “EMI” connection at the VFlex control board and at the EMI Board.	pg 4
16	Check the LCD Display for Error Messages.	pg 40
17	Not applicable to this model.	
18	Check 4 Amp fuse on the control board.	pg 4
19	Manually adjust any setting on the Control Board to clear all wireless override settings.	
20	Check for 24VAC out from the Toroidal Transformer and Power Harness.	pg 3, 18
21	Check the EMI Cable and contacts between the EMI Board and the VFlex Board.	pg 2, 4
22	Check the required entrapment protection sensors.	pg 10-11, 22, 28-29
?	The Control Board or EMI board may be damaged. Call Support for further assistance.	

Appendix (A)

Access Control Connections

Power Connections

The control board provides a 24VDC output to power external devices and controls. Alternatively, for devices that require a power supply other than 24VDC, the operators Power Box contains a convenient 120VAC receptacle to connect a plug-in transformer.

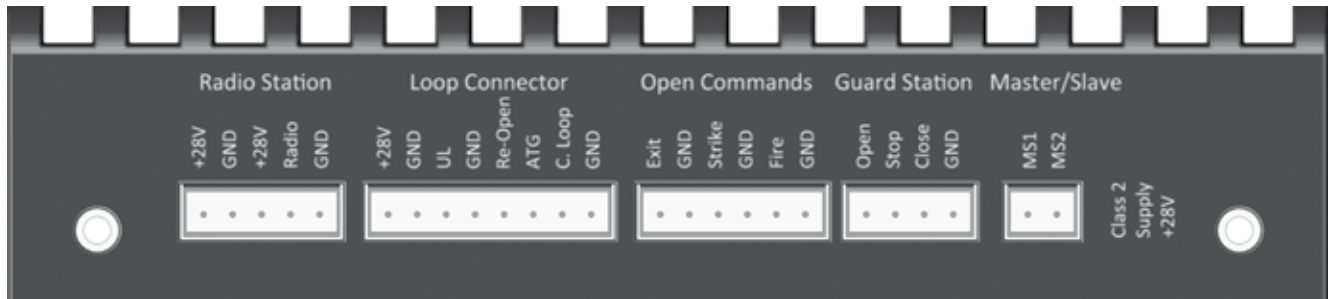

“C”	=	Common
“N.O.”	=	Normally Open

Terminals Connections and Input Functions:

Viking Terminal	Function	Device Terminal
“+28V”	DC Positive	“+”
“GND”	DC Negative	“-”
“GND”	Relay Common	“C”
“Radio”		“N.O.”
	If “Timer” OFF: Open - Stop - Close	
	If “Timer” ON: Open / Reopen if closing	
“UL”	(see pages 10-11 & 28)	“N.O.”
	If stopped: Prevents the gate from moving	
	If traveling: Stops then reverses gate momentarily	
“Re-Open”	(see pages 10-11 & 29)	“N.O.”
	If stopped: No function	
	If closing: Stops then Opens gate	
“ATG” Anti-Tailgate		“N.O.”
	Input is received: Stops gate if closing	
	Input is released: Closes gate to prevent tailgating	
“C. Loop”		“N.O.”
	If not at open limit: No function	
	If at open limit: Prevents gate from Closing	
“Open”, “Exit”, “Fire” & “Strike”		“N.O.”
	If stopped: Opens gate	
	If closing: Stops then Opens gate	
“Stop”		“N.O.”
	If traveling: Stops gate	
“Close”		“N.O.”
	If stopped: Closes gate	
	If traveling: No function	

⚠ TECHNICAL TIP: Each input Terminal (i.e. Radio, Exit, Re-Open, UL) has a corresponding Status LED that when illuminated indicates an input is currently being provided to the terminal and the gate is responding accordingly. (See pages 36-37 LED References)

Relays In General

NOTE: Viking Access Systems does not provide the external safety devices and access controls. These items can be purchased from your dealer or distributor.

In General

In regards to the Viking control board, all external safety devices and access controls contain, and are, simple relays that provide an input to the Viking control board when the device is activated.

When these devices are activated, their internal relays create a contact, or short, between the “C” and “N.O.” terminals. This contact is what provides the command to the Viking control board.

▲ TECHNICAL TIP: Viking uses the Normally Open “N.O.” contact from the device, excluding “fail-safe” type photo beams. In such instances, the Normally Closed “N.C.” will be used instead.

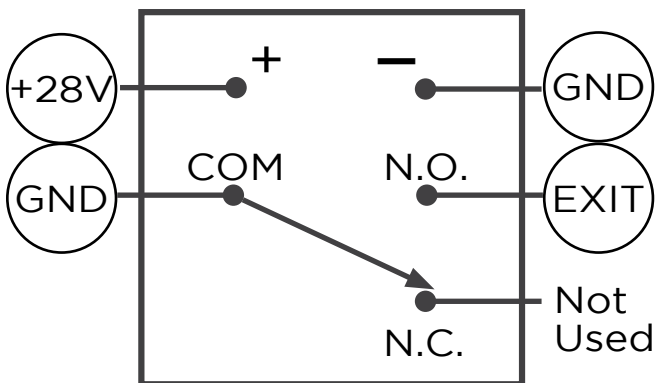

Glossary of Terms

- 1. Terminal:** Wire Connections.
- 2. Input Terminal:** On the Viking control board, the terminal which is labeled for a specific command (Re-Open, Exit, Radio, etc.). The N.O. contact from the access control device is to be connected to the Input Terminal.
- 3. Terminal Block:** On the Viking control board, a removable block containing multiple terminals.
- 4. Relay:** The component of an access control or safety device that provides an input or command to the Viking control board.
- 5. “C” Relay Common Terminal:** This is the relay terminal that makes contact (a short) to the N.O. terminal when the device is activated. *Always wire this relay terminal to any “GND” terminal at the control board.*
- 6. “N.O.” Relay Normally Open Terminal:** The relay terminal that has an open contact to “C” while the relay is not activated, and a closed contact when the relay is activated. *Almost always wire this relay terminal to an “Input Terminal” at the control board,*
- 7. “N.C.” Relay Normally Closed Terminal:** The relay terminal that has a closed contact to “C” while the relay is not activated, and an open contact when the relay is activated. *This terminal is rarely used.*
- 8. Relay Coil:** Contains the terminals that provide power at the relay.
- 9. “+” Relay Positive Terminal:** The positive power pole for the relay coil. *Always wire this relay terminal to any “+28V” terminal at the control board.*
- 10. “-” Relay Negative Terminal:** The negative power pole for the relay coil. *Always wire this relay terminal to any “GND” terminal at the control board.*

Appendix (B)

⚠ Cable use in Class 2 circuit to an external device shall be type CL2, CL2P, CL2R, CL2X or other cable with equivalent or better electrical, mechanical, and flammability ratings.

Common Radio Receivers - Connections

Multi Code 1099

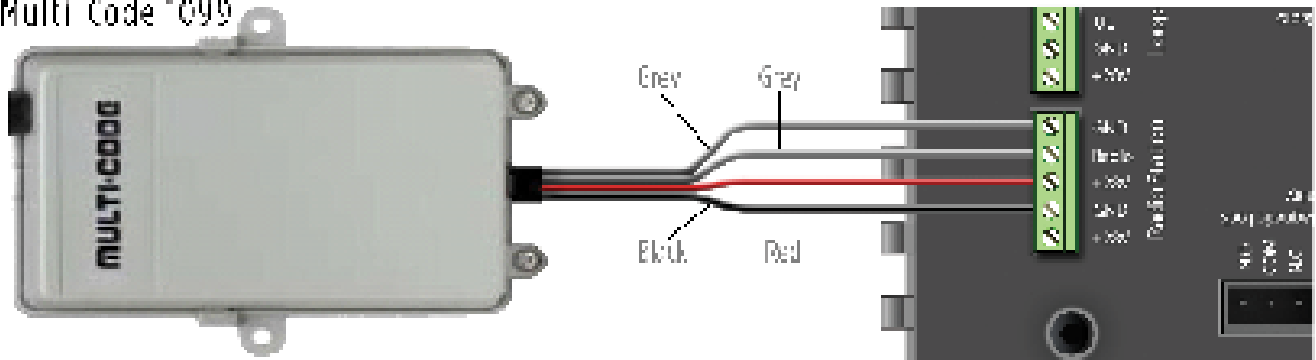

Multi Code 1090

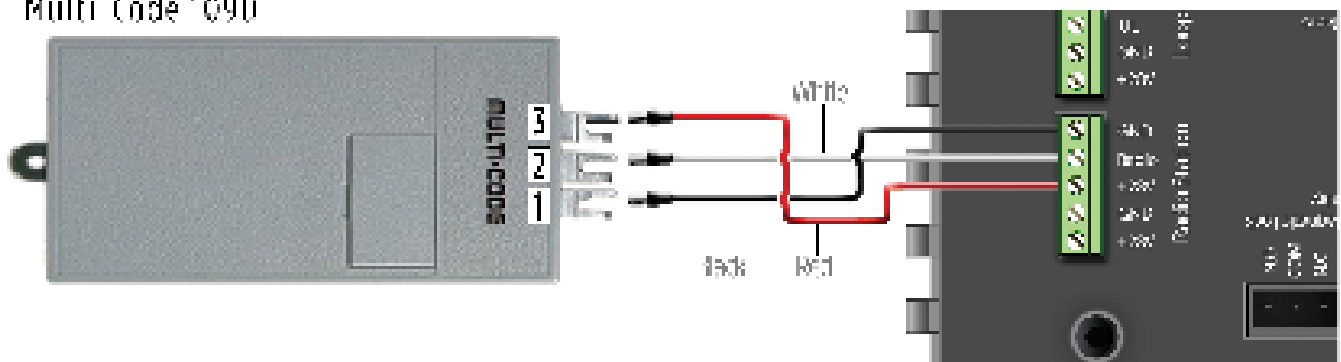

Liftmaster 317HM

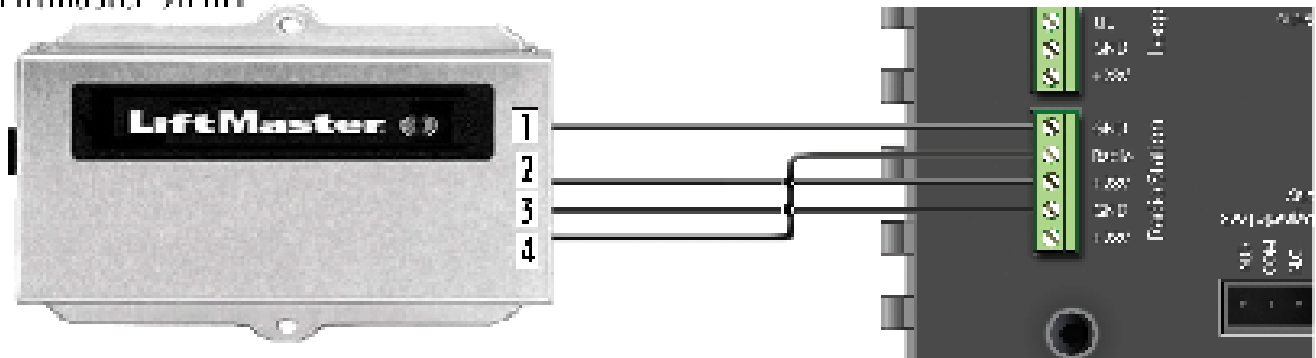

Linear Della 3 GRD

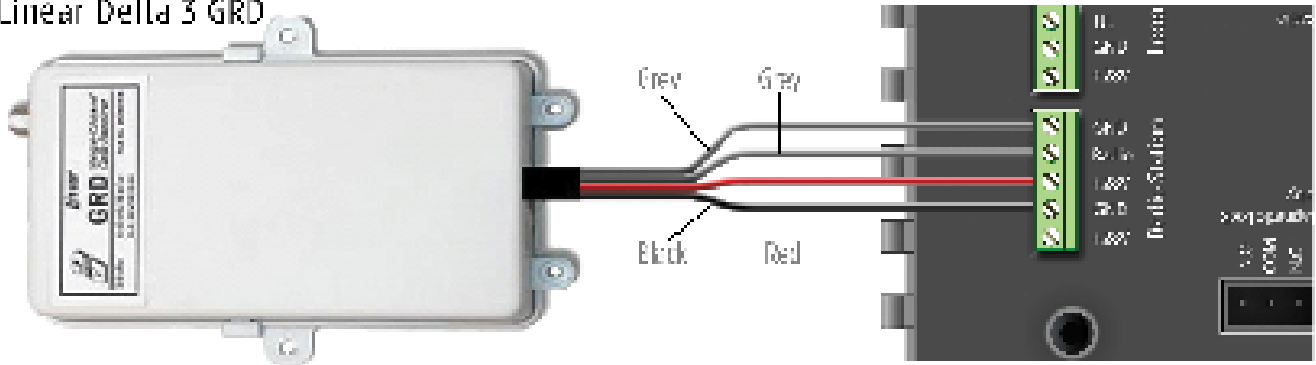

Solar Applications

NOTE: Viking recommends Solar Package (**part # VA-SOCHP**) for most general solar applications. Alternatively, individual and third party solar components can be used. The following are minimum system requirements and installation information.

Panels

- Voltage 24V
- Wattage 80W (minimum)

Cut the wires coming from the toroidal transformer.

Connect the solar panel cables to the power harness as shown.

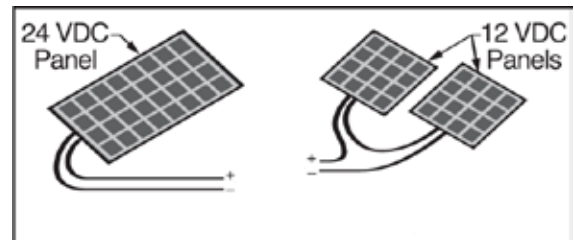

Batteries & Fuse

- Voltage 24V
- Amp Hour 35Ah (minimum)
- Fuse 10A (minimum)

Replace the operators batteries with 35Ah or greater.

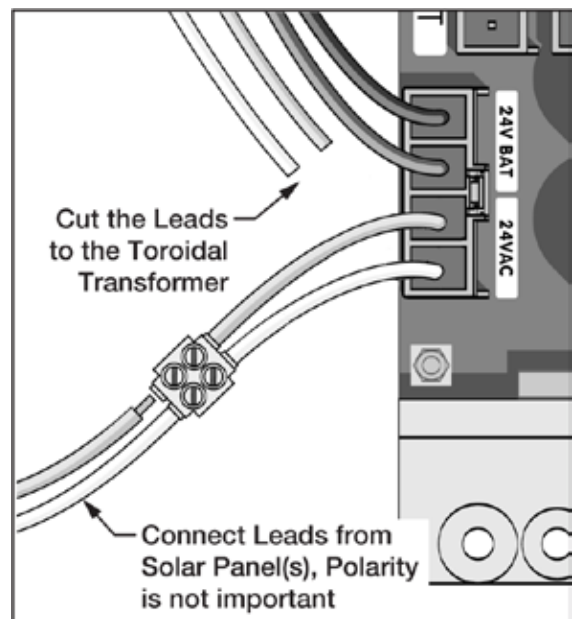
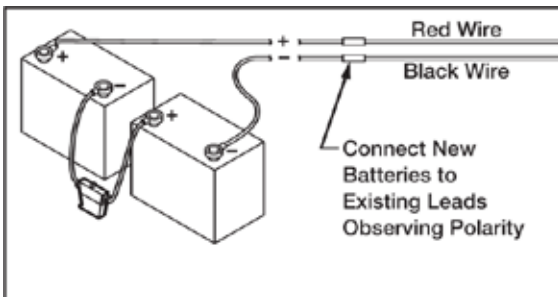

⚠ IMPORTANT: The chart provided can be used as a guide for the number of cycles the gate will operate per day. The chart is for a single gate operator with just:

- One Radio Receiver
- One low voltage, low current loop detector
- One low voltage, low current photo beam

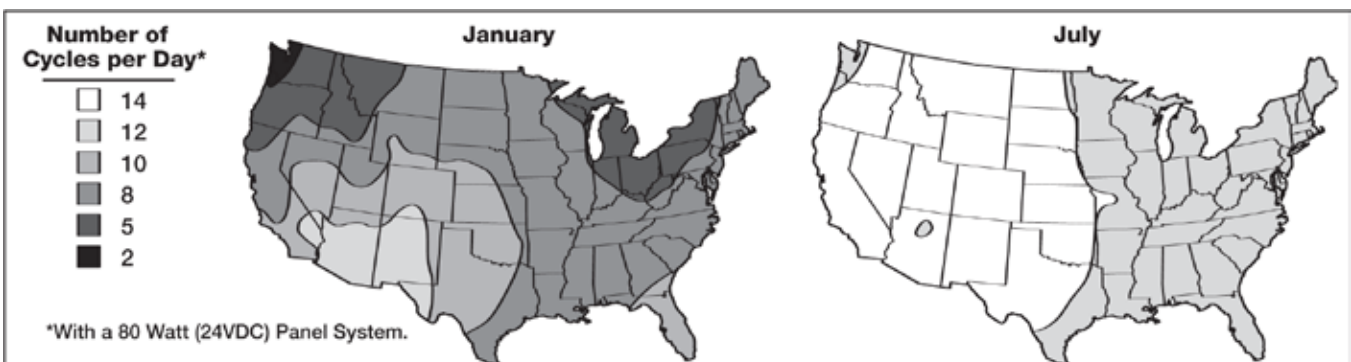

If more specific information is needed please consult with Viking Access Systems. For more information regarding solar energy refer to www.nrel.gov/solar